



Committing to the future

2010

## Measurement Engineering for Heating and Installation



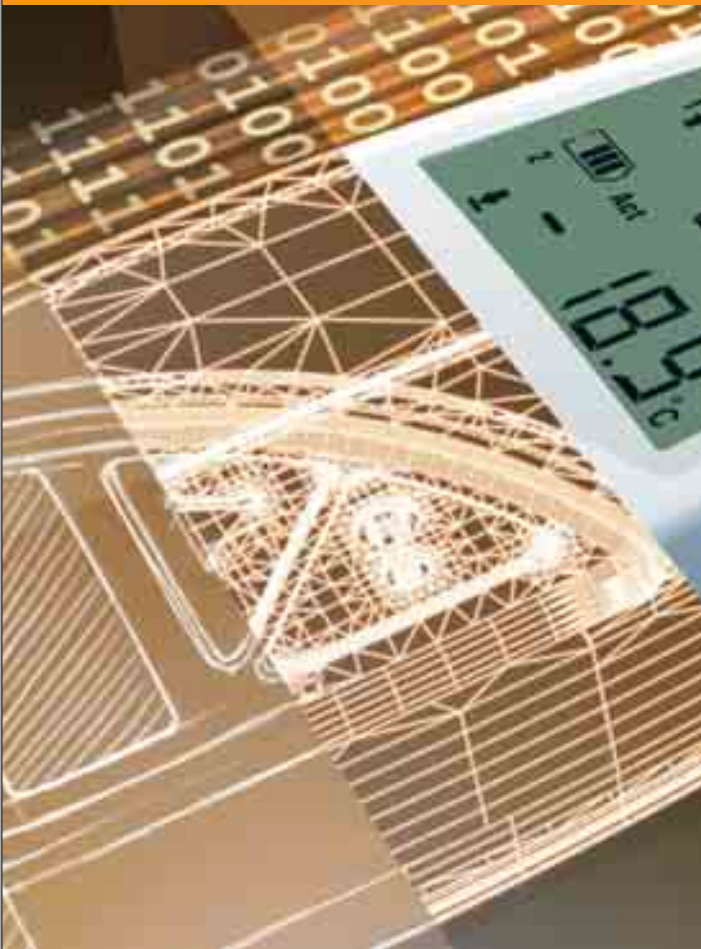

# Combustion points under control

**New opportunities:** The market for the supply of heat to buildings is changing constantly. Solar systems, heat pumps and other technologies, integrated concepts for energy supply and electronic control systems have established themselves. The objectives remain the same - demand controlled heat supply, low energy consumption and low emissions.

Regardless of the technology involved – every furnace must function 100%; regular checks and tuning are therefore required. Our contribution: We supply the best measurement engineering. We follow all developments attentively, we are there wherever there is something going on. We recognise trends far in advance and can therefore offer well-engineered applications ahead of the competition. You have rewarded us for our commitment by making us number one worldwide in the heating engineering sector.

## **Playing it safe.**

Measuring instruments must be reliable and efficient. For this reason, once developed we do not regard our products as being ready for the market. Instead, we subject them to tough tests in the field. It is only when these tests are successful that we start with serial production. All measuring instruments which leave our factory undergo quality inspections.

## **Spoilt for choice?**

It is impossible to find another product line with so many well-engineered, mobile gas analysers as we have. We admit that that could sometimes make the decision more difficult for you but you are guaranteed that you are working with the best suited product for your measurement job. Regardless for which flue gas analyser you decide, you can be assured that the gas paths are optimised i.e. are kept as short as possible. Susceptibility and corrosion are thus avoided. The results of your measurements are made available immediately. User-friendly and intelligible operation, a well thought-out accessory and measurement case system ensure that you can work – efficiently, fast and professionally.

#### Electrochemical gas sensors with added value!

The sensors specially developed for Testo have an above-average lifetime of 2-3 years. The extended service life of sensors in testo 330 LL by up to 6 years for O<sub>2</sub> and CO is revolutionary and enormously reduces follow-on costs for the user. Another outstanding feature is measuring instruments in which you can exchange the sensor yourself – without the need for test gas calibration. Back in operation immediately – couldn't be quicker.

#### The cheapest measuring instrument sometimes turns out to be the most expensive...

Heating problems in Winter. A true emergency! And your flue gas analyser breaks down today of all days! This is where we come in. We are proud of the top quality service we provide.

#### Learning changes

What was that? What flue gas flows are permitted according to the regulations governing wood furnaces? We offer in-depth documentation and leaflets on Testo Measurement Engineering, current standards and guidelines and their implementation.

## "Do you have a heating fitter in R&D?"



Edgar Mesam,  
Mesam GmbH  
Heating and Plumbing

Edgar Mesam grins as he asks this question in the course of a conversation about the quality of our products. The committed owner of a heating and plumbing business in Bannholz has been a customer of Testo for many years. As a heating fitter, he is committed to protecting the environment. We asked him to speak about his experience with Testo products.

Edgar Mesam:

"We are mainly involved in the maintenance and upkeep of existing systems. It is not as spectacular as the installation of renewable energy technology (which we also do, of course) but the potential for saving energy is huge. A defective system can use more than 50% more energy compared with a system in good working order and just an incorrectly adjusted system can mean increased power consumption of 20 to 30%.

My most important tool for adjusting heating systems is first-class measurement engineering which I get from Testo – all-inclusive, from the flue gas analyser to the fiberscope and everything that goes with it. In my own experience – and I have been in the business for 20 years – no other manufacturer meets the requirements in the field like Testo does with its products.

Another important point: With Testo, I don't have to grapple with the measurement engineering I get, I can select what I need for my requirements from the wide range of equipment and accessories within an instrument line.

Keep up the good work! I'm already looking forward to the newest innovations which have always convinced me up to now!



# The right flue gas analyser for ev

testo 327

Page 6

testo 330-1 LL

Page 10

testo 330-2 LL

Page 12

testo 350-S

Page 16



# Every requirement

Top instrument for extreme demands

testo 350-S

Special long-life version for heating fitters and technicians

testo 330-1 LL

Special long-life version for chimneysweeps, customer service and maintenance technicians

testo 330-2 LL

Basic instrument for heating technicians and installation

testo 327-1

Convenient basic instrument for heating technicians and installation

testo 327-2

Checks O<sub>2</sub>, °C, hPa in oil and gas burners

testo 327-O<sub>2</sub>

Checks CO, °C, hPa in oil and gas burners

testo 327-CO

## Outline

	testo 327 CO	testo 327 O <sub>2</sub>	testo 327-1	testo 327-2	testo 330-1 LL	testo 330-2 LL	testo 350-S
Adjusting efficiency: TÜV approved O <sub>2</sub> , CO <sub>2</sub> , qA, °C, λ							
Combustion quality: CO flue gas							
Up to 2000 ppm, for gas systems							
Up to 4000 ppm, for gas or oil systems with low pollution							
8000 ppm, for oil systems with a high pollution level				Opt.			
30,000 ppm, for oil systems with extreme pollution and solid fuel systems							Opt.
NO for low NOx inspections					Opt.	Opt.	Opt.
Flue draught							
Differential temperature, adjusting flow and return temperatures							
Protection of CO sensor via switch-off function							Autom.
Differential pressure, for adjustment of pressure ratios in gas systems, mbar/hPa				40/200	40/200	40/200	40/200
Probe for detecting gas leaks							
Protection: Probe for measuring ambient CO							
Printout with date and time							
Audible/optical alarm for ambient CO and gas leak detection							
Immediate stand-by: Convenient sensor exchange without entering coefficient							
Allocation and processing of information (analysis software)				Opt.	Opt.	Opt.	Opt.
Built-in data memory, no. of data blocks:				20	200	400	250,000 readings
Transmission of readings to PC				IrDA	USB	USB	RS 232
Transmission of values to Pocket PC via IrDA				IrDA	IrDA	IrDA	
Wireless transfer of values to Pocket-PC via BLUETOOTH®				Opt.	Opt.	Opt.	Opt.
Printer connection with print text							
Barcode connection							
State inspection: TÜV approved CO				Opt.			

## testo 308 – control and service instrument for chimney sweeps and heating engineers

### Finally: The real measurement, thanks to digital soot count determination

The new electronic testo 308 will replace the time-consuming determination of smoke count used up to now. The manual measurement of smoke count, which has been used for decades, is history. This new technology not only offers more convenience, but also a degree of precision never before achieved in this price class – high-tech for trade experts and chimneysweeps.

Whether as a tough tool for flue gas measurements on all kinds of oil burners, or as a starter instrument for new tasks in service and maintenance – the testo 308 is fast, system-compatible, extremely reliable and always ready for use.

**NEW!**

Now with

 **Bluetooth®**  
Wireless transmission

Country permits for **BLUETOOTH®** wireless transfer for the smoke tester testo 308 and the flue gas analyzers testo 327-2 and testo 330 LL

The **BLUETOOTH®** radio module used by Testo is permitted for the following countries and may only be used in those countries, i.e. the **BLUETOOTH®** wireless transmission may not be used in any other country!

**Europe including all EU member states**  
Austria, Belgium, Bulgaria, Czech Republic, Cyprus, Denmark, Estonia, Finland, France, Germany, Great Britain, Greece, Hungary, Ireland, Italy, Latvia, Luxembourg, Malta, Netherlands, Poland, Portugal, Romania, Sweden, Slovakia, Slovenia, Spain and Turkey

**European countries (EFTA)**  
Iceland, Liechtenstein, Norway, Switzerland

**Non-European countries**  
Ukraine, Colombia und El Salvador



Automatic measurement – digital soot count measurement to one decimal space with constant sampling



High accuracy – the heated measurement spot avoids measurement errors due to condensation



Infrared interface – time-savings thanks to automatic evaluation and digital transfer of measurement values



Fast and easy exchange of the LI-ion battery



## testo 308 – the electronic smoke tester

### testo 308

testo 308 is the instrument for easy electronic soot count measurement. It records the soot count digitally to one decimal space with constant sampling. The powerful LED backlighting guarantees good legibility even under poor light conditions. The instrument excels through its easy menu structure and ergonomic pistol grip.

- Easy, self-explanatory menu
- Clear segment display
- LED display illumination
- Easy IR printout
- Integrated condensate trap (evacuatable)
- Integrated dirt filter (exchangeable)
- TÜV tested
- Additional soot count determination on filter paper
- Li-ion battery, (2600 mA, 45 individual measurements), chargeable inside or outside the instrument
- Mains operation possible
- Battery and charger from testo 327 and testo 330 can be used
- BLUETOOTH interface (optional)
- Easy exchange of soot filter roll
- Spare battery chargeable separately or in instrument
- Protection class IP40



1. BImSchV  
TÜV By RgG 269

Technical data	
Optical analysis	
Sensor	Photodiode
Meas. range	0 to 6 RZ
Resolution	0.1 RZ
Accuracy	±0.2 RZ
Measurement sample volume	
Pump capacity	1,63 ± 0,1 l
Reference filter	at 990 mbar and +20 °C ambient temperature
Dimensions, Weight	
Dimensions	270 x 63 x 120 mm
Weight	600 g incl. battery
Power supply	
Rech. battery	Lithium ion battery, 2600 mA
Battery life	45 individual measurements
Battery charge	in the instrument via mains unit or externally by charger
General technical data	
Display	Segment display with background illumination
Norms and tests	1. BImSchV, METAS, EU-guideline 2004/108/EG
Oper. temp.	0 to +40 °C
Storage temp.	-20 to +50 °C
Protection class	IP40
Interfaces	IR/IRDA interface, BLUETOOTH®
Gas sampling	Stainless steel pipe ca. 220 mm, rubber hose 100 mm
Warranty	2 years



A convenient pistol grip ensures that the instrument fits comfortably into the hand. This allows easy one-hand operation.



The integrated condensate trap can be evacuated.



The high-contrast display is backlit and has a self-explanatory menu

#### testo 308

testo 308 smoke tester incl. rechargeable battery and calibration protocol for measuring soot count

Part no. 0632 0308

#### testo 308 / BLUETOOTH®

testo 308 smoke tester with BLUETOOTH® interface incl. rechargeable battery and calibration protocol for measuring soot count

Part no. 0632 0309

#### Set testo 308

Set testo 308 smoke tester incl. mains unit and bag

Part no. 0563 3080

#### Set testo 308 / BLUETOOTH®

Set testo 308 smoke tester with BLUETOOTH® interface incl. mains unit and bag

Part no. 0563 3090

#### Accessories Ordering data

Accessories Ordering data	Part no.
Instrument bag for smoke tester testo 308	0516 0002
100-240 V AC / 6.3 V DC international mains unit, for mains operation or battery charging in instrument	0554 1096
Probe holder for smoke tester testo 308 and flue gas probes	0554 0616
Spare battery 2600 mA	0515 0107
Charger for spare battery	0554 1103
Spare soot filter paper (8 paper rolls)	0554 0146
Spare dirt filters (10 off)	0554 1101
Cone with fixing screw	0554 9010
Testo fast printer with wireless infrared interface, 1 roll thermal paper and 4 AA batteries	0554 0549
Basic system case for analyzer, probes and accessories	0516 3330
Shaft length 330 mm, suitable for smoke tester testo 308	0440 1115

## testo 327 – Robust and fast-action flue gas analyser for all important parameters

### Do you manage to get home by 5pm every day?



Hans-Dieter Guth,  
Market Manager  
Contractors BU,  
Germany

Probably not, because your job expects above-average dedication. You also need partners who won't let you down. We are leading the way with our quality

service. Check it out for yourself.

Do you need an accessory, do you have a question about measuring or do you need a replacement instrument? – Testo Service employees are at your service in many locations – also near you. Good to know when the situation requires.



Excellent display clearness even in unfavourable lighting conditions



Fast probe connection: All gas paths are connected with one "click"



Sensors are as easy to change as a battery



Latest Li-ion rechargeable batteries



## testo 327-1 – Basic instrument for heating and installation technicians

### testo 327-1

testo 327-1 is your introductory instrument to flue gas analysis. It measures combustion efficiency, °C, O<sub>2</sub>, CO<sub>2</sub>, CO and flue draught. The strong LED background light in the 4 line display guarantees an easy-to-read display even if lighting conditions are unfavourable. The analyser stands out on account of its easy menu navigation and ergonomic housing as well as its durability.

- Easy menu navigation
- 4 line segment display
- LED display light
- Easy IR printout
- Built-in condensate trap
- TÜV By RgG 253 acc. to 1. BlmSchV
- EN 50379 Part 2 for O<sub>2</sub>, °C, hPa
- EN 50379 Part 3 for CO
- Small Li-ion rechargeable battery (1200 mA, lifetime of 5 h) can be recharged inside or outside instrument
- Fast probe connection using single probe plug
- Ambient CO measurement using flue gas probe
- O<sub>2</sub> dual wall measurement (can be stored)
- Separate AT temperature measurement
- Undiluted CO measurement (can be stored)
- Draught measurement
- 6-8 fuels (country-specific (e.g. UK=6))
- IP 40



Stable probes filter particles before they get into gas paths



Built-in condensate trap



The "second skin" is integrated into the instrument design and protects from impact and shock during tough everyday use

#### testo 327-1

testo 327-1 flue gas analyser, rechargeable battery and calibration protocol included, measures O<sub>2</sub>, CO, hPa and °C

Part no. 0632 3201

#### testo 327-1 CO

testo 327-1 CO flue gas analyser, rechargeable battery and calibration protocol included, measures CO, hPa and °C

Part no. 0632 3204

#### testo 327-1 O<sub>2</sub>

testo 327-1 O<sub>2</sub> flue gas analyser, rechargeable battery and calibration protocol included, measures O<sub>2</sub>, hPa and °C

Part no. 0632 3203



Technical data	
Temperature measurement	-40 to +600 °C
Draught measurement	±40 hPa
Efficiency measurement (Eta)	0 to 120%
Flue gas loss (qA)	0 to 99.9%
O <sub>2</sub> measurement	0 to 21 Vol. %
CO <sub>2</sub> measurement	0 to CO <sub>2</sub> max
CO measurement	0 to 4000 ppm
Weight	Approx. 500 g
Dimensions	216 x 68 x 47 mm
Storage temp.	-20 to +50 °C
Oper. temp.	-5 to +45 °C
Power supply	via Li-Ion rechargeable battery
Battery life	> 5 h
Warranty	2 years on instrument, probes and gas sensors 1 year on thermocouple and rechargeable battery (wearing parts excluded)

### testo 327-1 Basic Set for heating and installation technicians

- testo 327-1 flue gas analyser incl. rech. batteries and calibration protocol
- Mains unit 100-240 V for mains operation or battery charging in instrument
- Compact flue gas probe, 180 mm long, Ø 6 mm
- Combustion air temperature probe, immersion depth 190 mm
- Fast printer with wireless infrared interface
- Instrument cleaner 100 ml
- Basic system case for instrument, probes and accessories

Part no. 0563 3203 70



## testo 327-2 – Service instrument for heating technicians and inspectors

### testo 327-2

The testo 327-2 service analyzer measures combustion efficiency, °C, O<sub>2</sub>, CO<sub>2</sub>, CO and flue draught. The bright LED backlight in the 4-line display guarantees an easy-to-read display even if lighting conditions are unfavourable. The analyzer stands out on account of its easy menu navigation and ergonomic housing as well as its durability. testo 327-2 enthruses the user with additional useful features such as the data store (20 measurements), differential temperature measurement to determine flow and return temperatures or differential pressure measurement to adjust pressure ratios in gas systems. Official measurements on gas burners in accordance with EN 50379 Part 2 are also possible thanks to the option of a H<sub>2</sub> compensated CO sensor. The IrDa interface opens communication options with a Pocket PC.

- Life expectancy of gas sensors up to 3 years
- Assurance thanks to instrument and sensor diagnosis
- IR and IRDA interface for easy reading out of data to printer or Pocket PC
- BLUETOOTH® wireless transfer (optional)
- Delta T measurement
- Delta P measurement: 2 measurement ranges
- Store (20 readings)
- Li-ion rechargeable battery (2,400 mA), 10 hr lifetime
- TÜV By RgG 254 acc. to 1. BImSchV
- CO option with H<sub>2</sub> compensation
- Official test in accordance with EN standard 50379-2 for °C; O<sub>2</sub>, hPa, Part 3 for CO
- Optional Part 2 for CO with H<sub>2</sub> compensation



#### testo 327-2

testo 327-2 flue gas analyzer, rechargeable battery and calibration protocol included, measures O<sub>2</sub>, CO, hPa and °C

Part no. 0632 3202

**NEW!\***

Now with

**Bluetooth®**  
Wireless transmission

#### Technical data

Temperature measurement	-40 to +600 °C
Draught measurement	±40 hPa
Pressure measurement	±200 hPa
Efficiency measurement (Eta)	0 to 120%
Flue gas loss (qA)	0 to 99.9%
O <sub>2</sub> measurement	0 to 21 Vol. %
CO <sub>2</sub> measurement	0 to CO <sub>2</sub> max
CO measurement	0 to 4000 ppm
Option CO measurement (H <sub>2</sub> -compensated)	0 to 8000 ppm
Weight	Approx. 500 g
Dimensions	216 x 68 x 47 mm
Storage temp.	-20 to +50 °C
Oper. temp.	-5 to +45 °C
Power supply	via Li-ion rechargeable battery
Battery life	> 10 h
Warranty	2 years on instrument, probes and gas sensors 1 year on thermocouple and rechargeable battery (wearing parts excluded)

### testo 327-2 Set for heating fitters

- testo 327-2 flue gas analyzer incl. rech. battery and calibration protocol
- Including option: CO-H<sub>2</sub> measurement
- Mains unit 100-240 V for mains operation or battery charging in instrument
- Modular flue gas probe, 300 mm long, Ø 8 mm, TÜV approval
- Combustion air temperature probe, immersion depth 190 mm
- Hose connection set for separate gas pressure measurement
- Fast printer with wireless infrared interface
- Flexible probe shaft, 330 mm long, Ø 10 mm, Tmax. 180°C
- Instrument cleaner, 100 ml
- Basic system case for instrument, probes and accessories

Part no. 0563 3202 70

### Complete set testo 327-2 with smoke tester für heating constructors

- Exhaust gas analyzer testo 327-2 incl. battery and calibration protocol
- Including option: CO-H<sub>2</sub> measurement
- Smoke tester testo 308
- Mains unit 100-240 V for mains operation or charging the battery in the instrument
- Modular flue gas probe, length 300 mm, Ø 8 mm, TÜV tested
- Combustion temperature probe, immersion depth 190 mm
- Hose connection set for separate gas pressure measurement
- Fast report printer with wireless infrared interface
- Flexible probe pipe, length 330 mm, Ø 10 mm, Tmax. 180°C
- Instrument cleaner 100 ml
- Basic system case for instrument, probes and accessories

Part no. 0563 3202 77

### testo 327-2 Set for heating inspectors

- testo 327-2 flue gas analyzer incl. rech. battery and calibration protocol
- Including option: CO-H<sub>2</sub> measurement
- Mains unit 100-240 V for mains operation or battery charging in instrument
- Modular flue gas probe, 300 mm long, Ø 8 mm, TÜV approval
- Combustion air temperature probe, immersion depth 190 mm
- Dual wall clearance probe for measuring O<sub>2</sub> in input air
- CO multiple hole probe shaft, 300 mm long, Ø 8 mm
- Flexible probe shaft, 330 mm long, Ø 10 mm, Tmax. 180°C
- Instrument cleaner, 100 ml
- Basic system case for instrument, probes and accessories

Part no. 0563 3202 71

### Complete set testo 327-2 with smoke tester for chimneysweeps

- Exhaust gas analyzer testo 327-2 incl. battery and calibration protocol
- Including option: CO-H<sub>2</sub> measurement
- Smoke tester testo 308
- Mains unit 100-240 V for mains operation or charging the battery in the instrument
- Modular flue gas probe, length 300 mm, Ø 8 mm, TÜV tested
- Combustion temperature probe, immersion depth 190 mm
- Dual wall clearance probe for O<sub>2</sub> draught air measurement
- CO multiple hole probe pipe, length 300 mm, Ø 8 mm
- Flexible probe pipe, length 330 mm, Ø 10 mm, Tmax. 180°C
- Instrument cleaner 100 ml
- Basic system case for instrument, probes and accessories

Part no. 0563 3202 78

\*Country permits BLUETOOTH® wireless transfer cf. page 12

## Accessories testo 327

Instrument/Options	Part no.
testo 327-1 flue gas analyser, rechargeable battery and calibration protocol included, measures O <sub>2</sub> , CO, hPa and °C	0632 3201
testo 327-1 O <sub>2</sub> flue gas analyser, rechargeable battery and calibration protocol included, measures O <sub>2</sub> , hPa and °C	0632 3203
testo 327-1 CO flue gas analyser, rechargeable battery and calibration protocol included, measures CO, hPa and °C	0632 3204
testo 327-2 flue gas analyzer, rechargeable battery and calibration protocol included, measures O <sub>2</sub> , CO, hPa and °C	0632 3202
Upgrade/Options	Part no.
Option: CO-H <sub>2</sub> -measurement for testo 327	0440 3273
Option: fine draught measurement, resolution 0.1 Pa, measurement range up to 100 Pa (instead of standard draught measurement) - for testo 327-1, 327-1 O <sub>2</sub> /CO and testo 327-2	0440 3271
Option: fine differential pressure measurement, resolution 1 Pa; for testo 327-2 only	0440 3272
Option: BLUETOOTH® module	0344 0011
Retrofits	Part no.
Retrofit: O <sub>2</sub> measurement for testo 327-1 CO	
Spare sensors	Part no.
Spare O <sub>2</sub> sensor for testo 327-1, 327-1 O <sub>2</sub>	0390 0047
Spare CO sensor for testo 327-1, 327-1 CO	0390 0046
Spare O <sub>2</sub> sensor, Testo-specific	0390 0092
Spare CO sensor, Testo-specific, (without H <sub>2</sub> compensation)	0390 0095
Spare CO sensor, Testo-specific (H <sub>2</sub> compensated)	0390 0109
Accessories	Part no.
100-240 V AC / 6.3 V DC international mains unit for mains operation or battery charging in instrument	0554 1096
Spare rech. batt. w/ charging station	0554 1087
Li-ion battery pack	0515 0100
Testo fast printer with wireless infrared interface, 1 roll thermal paper and 4 AA batteries	0554 0549
Spare thermal paper for printer (6 rolls), permanent ink	0554 0568
Instrument cleaner (100 ml)	0554 1207
Smoke tester with oil, soot sheet, for measuring soot in flue gas	0554 0307
Spare soot filter paper (8 paper rolls)	0554 0146
Hose connection set for separate gas pressure measurement	0554 1203
Full version easyheat and easyheat.mobile. Software package for PC and Pocket PC. (for testo 327-2 only)	0554 1210
ISO calibration certificate/flue gas	0520 0003
Differential temperature set consisting of 2 Velcro probes and temperature adapter	0554 1208
Spare particle filter (10 off)	0554 3385
Cases	Part no.
Basic system case for instrument, probes and accessories	0516 3334
Probes	Part no.
<b>Compact basic flue gas probes available in two lengths, probe stop, NiCr-Ni thermocouple, 1.5 m hose and particle filter included</b>	
Compact flue gas probe, 180 mm long, Ø 6 mm, Tmax. 500 °C	0600 9740
Compact flue gas probe, 300 mm long, Ø 6 mm, Tmax. 500 °C	0600 9741
<b>Modular flue gas probe from the testo 330 product line, available in 2 lengths, probe stop, NiCr-Ni thermocouple, 2.2 m hose and particle filter included</b>	
Flue gas probe, 180 mm long, Ø 8 mm, Tmax 500 °C, TÜV approval	0600 9760
Flue gas probe, 300 mm long, Ø 8 mm, Tmax 500 °C, TÜV approval	0600 9761
Flue gas probe, 180 mm long, Ø 6 mm, Tmax 500 °C	0600 9762
Flue gas probe, 300 mm long, Ø 6 mm, Tmax 500 °C	0600 9763
Flexible flue gas probe, 330 mm long, Tmax. 180 °C, short-term 200 °C, bending radius max. 90° for measuring at inaccessible points	0600 9764
<b>Probe accessories</b>	
Probe shaft, 180 mm long, Ø 8 mm, Tmax 500 °C	0554 9760
Probe shaft, 180 mm long, Ø 6 mm, Tmax 500 °C	0554 9762
Probe shaft, 300 mm long, Ø 8 mm, Tmax 500 °C	0554 9761
Probe shaft, 335 mm long, with probe stop, Ø 8 mm, Tmax 1000 °C	0554 8764
Flexible probe shaft, 330 mm long, Ø 10 mm, Tmax 180 °C	0554 9764
Multi-hole probe shaft, 300 mm long, Ø 8 mm, for mean CO calculation	0554 5762
Multi-hole probe shaft, 180 mm long, Ø 8 mm, for mean CO calculation	0554 5763
Modular flue gas probe handle	0440 3334
Hose extension, 2.8 m, extension cable for probe and analyser	0554 1202
8 mm probe stop, steel, with spring clamp and handle, Tmax 500 °C	0554 3330
6 mm, probe stop, steel, with spring clamp and handle, Tmax 500 °C	0554 3329
<b>Additional probes</b>	
Dual wall clearance probe for O <sub>2</sub> supply air measurement	0632 1260
<b>Combustion air temperature probes</b>	
Combustion air temperature probe, immersion depth 300 mm	0600 9791
Combustion air temperature probe, immersion depth 190 mm	0600 9787
Combustion air temperature probe, immersion depth 60 mm	0600 9797
Quick-action surface probe with sprung thermocouple strip, measuring range short-term to +500 °C	0604 0194

## testo 330-1 LL – Flue gas analysis with increased convenience and reliability

### You are looking at the technical edge.

The extended service life of the sensors in testo 330-1 LL by up to 6 years for O<sub>2</sub> and CO greatly reduce follow-on costs for the user. At least one O<sub>2</sub> and one CO sensor change can be dispensed with during typical utilisation of the instrument. In addition, Testo offers a four year warranty on the complete instrument (testo 330-1 LL with O<sub>2</sub> and CO measurement sensors and probe).

User-friendly operation  
Robust quick-action  
probe connection for all  
gas paths

Increased safety  
Qualitative status of  
functions and wearing  
parts via instrument  
diagnosis

More convenience  
Easy-to-change rech.  
batt. and sensors, rech.  
batt. life > 8 hours, sensor  
life > 6 years

Absolutely robust  
High CO display range up  
to 30,000 ppm on  
account of patented  
dilution (testo 330-2 LL)

**NEW!**

Now with

**Bluetooth®**  
Wireless transmission

Country permits for BLUETOOTH® wireless transfer for the smoke tester testo 308 and the flue gas analyzers testo 327-2 and testo 330 LL

The BLUETOOTH® radio module used by Testo is permitted for the following countries and may only be used in those countries, i.e. the BLUETOOTH® wireless transmission may not be used in any other country!

**Europe including all EU member states**  
Austria, Belgium, Bulgaria, Czech Republic, Cyprus, Denmark, Estonia, Finland, France, Germany, Great Britain, Greece, Hungary, Ireland, Italy, Latvia, Luxembourg, Malta, Netherlands, Poland, Portugal, Romania, Sweden, Slovakia, Slovenia, Spain and Turkey

**European countries (EFTA)**  
Iceland, Liechtenstein, Norway, Switzerland

**Non-European countries**  
Ukraine, Colombia und El Salvador



## Convenient introductory analyser in the pro class for heating technicians and fitters

### testo 330-1 LL

The major advantage of flue gas analysers lie in their dialog feature: instrument diagnosis provides information about the qualitative status of functions at the touch of a button; for example, the level in a condensate trap but also wearing parts such as the condition of the gas sensors. Maintenance intervals are displayed allowing you to plan better. The times when an analyser let the user down all of a sudden are a thing of the past.

Modular probes such as  $\Delta T$ ,  $\Delta P$ , flue gas are recognised automatically by the analyser so that measurement results appear immediately in the display.

The probes have a probe quick-release device with which all of the gas paths are connected without mix-ups. The single cable is rigid, indestructible, saves space and creates order. The particle filter is located directly in the probe's handle. Probe shafts with different lengths and diameters can be easily attached to the probe handle.

- Instrument diagnosis
- $\Delta T$  measurement, flow/return
- Ambient CO measurement
- Ambient CO<sub>2</sub> measurement
- Detects gas leaks using gas leak detection probe
- $\Delta P$  measurement for gas pressure
- Gas/oil throughput
- 200 measurement data sets, system numbers included
- IRDA interface for data transfer to PDA/Notebook
- BLUETOOTH® wireless transfer (optional)\*
- USB interface for data transfer to PC
- TÜV By RgG 250 acc. to 1. BlmSchV
- Official test acc. to EN 50379-2 for O<sub>2</sub>, °C, hPa
- Official test acc. to EN 50379-3 for CO
- Data management with easyheat software (PC) and easyheat.mobile (Pocket PC)
- Interface to automatic burner



Flue gas measurement in a burner

#### testo 330-1 LL

testo 330-1 LL flue gas analyzer with long-life gas sensors, rechargeable battery and calibration protocol included

Part no. 0632 3304

# LL

**4 Year Warranty on Instrument and Probe (testo 330-1 LL)**

#### The new long-life set for heating fitters and technicians

testo 330-1 LL flue gas analyser with rech. battery and calibration protocol

Mains unit 100-240 V for mains operation or charging the battery in the instrument

Modular flue gas probe, immersion depth: 300 mm,  $\varnothing$  8 mm

Combustion air temperature probe, immersion depth: 190 mm

Hose connection set for separate gas pressure measurement

Fast IRDA printer

Flexible probe shaft, 330 mm long,  $\varnothing$  10 mm, T<sub>max</sub> 180 °C

Basic system case for instrument, probes and accessories

Part no. 0563 3324 70

See pages 18 + 19 for Accessories Ordering Data

#### Technical data

Temperature	-40 to +1200 °C
Draught measurement	-9.99 to +40 hPa
Pressure measurement	0 to 200 hPa
O <sub>2</sub> measurement	0 to 21 Vol. %
CO measurement (without H <sub>2</sub> compensation)	0 to 4000 ppm
Efficiency measurement (Eta)	0 to 120%
Flue gas loss	0 to 99.9%
CO <sub>2</sub> measurement	Display range 0 to CO <sub>2</sub> max
Option: NO <sub>low</sub> measurement	0 to 300 ppm
Option: NO measurement	0 to 3000 ppm
Ambient CO measurement (with CO probe)	0 to 500 ppm
Gas leak measurement for combustible gases (with gas leak detection probe)	Display range 0 to 10,000 ppm CH <sub>4</sub> / C <sub>3</sub> H <sub>8</sub>
Ambient CO <sub>2</sub> measurement (with ambient CO <sub>2</sub> probe)	0 to 1 Vol. % 0 to 10000 ppm

#### General Technical data

Memory	200 sites
Weight	600 g (without rechargeable battery)
Dimensions	270 x 90 x 65 mm
Storage temp.	-20 to +50 °C
Oper. temp.	-5 to +45 °C
Display	Graphics display 160 x 240 pixel
Power supply	Rech. batt. block 3.7 V / 2.2 Ah Mains unit 6 V / 1.2 A
Warranty	Instrument/probe/gas sensors (O <sub>2</sub> , CO) 4 years NO, NOlow sensor 2 years Thermocouple and rech. battery 1 year



## The flue gas analyzer with Longlife sensors and integrated draught/gas zeroing

### testo 330-2 LL

The flue gas analyser is a reliable companion regardless of whether it is for breakdowns or emergencies, monitoring legal limits or used during everyday maintenance. It supports a fast switch between measurement and maintenance. It can remain positioned in the flue during draught and flue gas zeroing. For applications under extreme conditions, such as badly polluted furnaces, Testo's patented technology guarantees reliable display of a CO value up to 30,000 ppm.

- Instrument diagnosis
- Automatic instrument leak-proofness test
- $\Delta T$  measurement, flow/return
- Ambient CO measurement
- Ambient CO<sub>2</sub> measurement
- Detects leaks with gas leak detection probe
- $\Delta P$  measurement for gas pressure
- Gas/oil throughput
- 400 measurement data sets incl. site address and system no.

- IRDA interface for data transfer to Pocket PC/notebook
- USB interface for data transfer to PC
- Interface to automatic furnaces
- TÜV By RgG 251 acc. to 1. BlmSchV
- Official test acc. to EN 50379-2 for O<sub>2</sub>, °C, hPa und CO
- Draught zeroing without probe removal. The probe can remain in the flue during zeroing
- Zeroes flue gas sensors without probe removal



Now: 4 year guarantee on instrument and probe



More robust, longer living, faster and safer thanks to extended lifetime



Fast monitoring of flue gas values in heating systems

#### Technical data

Temperature	-40 to +1200 °C
Draught measurement	-9.99 to +40 hPa
Pressure measurement	0 to 200 hPa
O <sub>2</sub> measurement	0 to 21 Vol. %
CO measurement (H <sub>2</sub> compensated)	0 to 8000 ppm from 8000 ppm display range 8000 to 30000 ppm (automatic dilution)
Efficiency measurement (Eta)	0 to 120%
Flue gas loss	0 to 99.9%
CO <sub>2</sub> measurement	Display range 0 to CO <sub>2</sub> max
Option: NO <sub>low</sub> measurement	0 to 300 ppm
Option: NO measurement	0 to 3000 ppm
Ambient CO measurement (with CO probe)	0 to 500 ppm
Gas leak measurement for combustible gases (with gas leak detection probe)	Display range 0 to 10.000 ppm CH <sub>4</sub> / C <sub>3</sub> H <sub>8</sub>
Ambient CO <sub>2</sub> measurement (with ambient CO <sub>2</sub> probe)	0 to 1 Vol. % 0 to 10000 ppm

#### General technical data

Memory	400 sites
Weight	600 g (without rechargeable battery)
Dimensions	270 x 90 x 65 mm
Storage temp.	-20 to +50 °C
Oper. temp.	-5 to +45 °C
Display	Graphics display 160 x 240 pixel
Power supply	Rech. block 3.7 V / 2.2 Ah Mains unit 6 V / 1.2 A
Warranty	Instrument/probe/gas sensors (O <sub>2</sub> , CO) 4 years NO, NOlow sensor 2 years Thermocouple and battery 1 year

#### testo 330-2 LL

testo 330-2 LL flue gas analyser with long-life gas sensors and built-in draught and gas zeroing, rech. batt. and calibration protocol included

Part no. 0632 3305

**NEW!**

Now with

**Bluetooth®**  
Wireless transmission

Country permits for BLUETOOTH® wireless transfer for the smoke tester testo 308 and the flue gas analyzers testo 327-2 and testo 330 LL

The BLUETOOTH® radio module used by Testo is permitted for the following countries and may only be used in those countries, i.e. the BLUETOOTH® wireless transmission may not be used in any other country!

**Europe including all EU member states**  
Austria, Belgium, Bulgaria, Czech Republic, Cyprus, Denmark, Estonia, Finland, France, Germany, Great Britain, Greece, Hungary, Ireland, Italy, Latvia, Luxembourg, Malta, Netherlands, Poland, Portugal, Romania, Sweden, Slovakia, Slovenia, Spain and Turkey

**European countries (EFTA)**  
Iceland, Liechtenstein, Norway, Switzerland

**Non-European countries**  
Ukraine, Colombia und El Salvador

See page 18+19 for Accessories Ordering Data

## The new longlife sets testo 330-2 LL

### The new long-life set for customer service and maintenance technicians

testo 330-2 LL flue gas analyser

---

Mains unit 100-240 V for mains operation or charging battery in instrument

---

Modular flue gas probe, immersion depth: 300 mm, Ø 8 mm

---

Combustion air temperature probe, immersion depth: 190 mm

---

Hose connection set for separate gas pressure measurement

---

Fast IRDA printer

---

Flexible probe shaft, 330 mm long, Ø 10 mm, Tmax 180 °C

---

Basic system case for instrument, probes and accessories

**Part no. 0563 3325 70**

### The new longlife complete set for customer service and maintenance technicians with smoke tester

Exhaust gas analyzer testo 330-2 LL

---

Smoke tester testo 308

---

Mains unit 100-240 V for mains operation or charging the battery in the instrument

---

Modular flue gas probe, length 300 mm, Ø 8 mm

---

Combustion temperature probe, immersion depth 190 mm

---

Hose connection set for separate gas pressure measurement

---

Fast report printer IRDA

---

Flexible probe pipe, length 330 mm, Ø 10 mm, Tmax. 180°C

---

Basic system case for instrument, probes and accessories

**Part no. 0563 3325 77**



Illustration may differ from original!

### The new long-life set for heating inspectors

testo 330-2 LL flue gas analyser with rechargeable battery and calibration protocol

---

Mains unit 100-240 V for mains operation or recharging battery in instrument

---

Modular flue gas probe, immersion depth: 300 mm, ø 8 mm

---

Combustion air temperature probe, immersion depth: 190 mm

---

Hose connection set for separate gas pressure measurement

---

Flexible probe shaft, 330 mm long

---

Dual-wall clearance probe

---

Basic system case for instrument, probes and accessories

**Part no. 0563 3325 71**

### The new longlife complete set for chimneysweeps and inspectors with smoke tester

Exhaust gas analyzer testo 330-2 LL incl. battery and calibration protocol

---

Smoke tester testo 308

---

Mains unit 100-240 V for mains operation or charging the battery in the instrument

---

Modular flue gas probe, immersion depth 300 mm, Ø 8 mm, TÜV tested

---

CO multiple hole probe pipe for modular flue gas probe

---

Combustion temperature probe, immersion depth 190 mm

---

Hose connection set for separate gas pressure measurement

---

Flexible probe pipe, length 330 mm

---

Dual wall clearance probe

---

Basic system case for instrument, probes and accessories

**Part no. 0563 3325 78**



## Testo fine pressure probe – highest accuracy in the Pascal range

### How it works

- Direct connection to the flue gas analyzer testo 330 (software retrofittable free of charge)
- Parallel Delta P/draught measurement for flue gas analysis, displayed in the menu of the flue gas analyzer
- Separate menu with temporary storage.
- Gas pressure measurement can be carried out in logger operation – making long-term measurements possible
- Temperature probes can be connected for the measurement of the ambient temperature or surface temperature
- Thanks to the zero point adjustment at 1 second intervals, external temperature influences have no effect on the measurement value.
- The fine pressure probes can easily be attached at any measurement site – by loop or magnet.



### Technical data

Property	Values	
Parameter	Differential pressure	Sensor in probe
	Temperature	Thermocouple Type K, external, plug-in
Calculated variables	Velocity	Range 0.15 to 3 m/s Resolution 0.1 m/s
Differential pressure measurement	Measuring ranges	Meas. range 1 -149.99 Pa to +149.9 Pa Meas. range 2 -9999.9 Pa to -150.0 Pa +150.0 Pa to +9999.9 Pa
	Resolution	Meas. range 1 0.01 Pa Meas. range 2 0.1 Pa
	Accuracy	±0.3 Pa / ±3 % of mv ±1 digit (in the range 0 to +149.9 Pa) ±3 % of mv ±1 digit (in the range +150 to +9999.9 Pa)
	Measuring rate	<1 m.v./s
Temperature measurement	Meas. range	-200 to +300 °C
Surface probe	Resolution	0.1 °C
Zero point drift	(<±0.2 Pa (at +20 °C ±2 °C within 5 mins.))	
Operating temperature probe	+5 to +45 °C	
Operating temperature Pitot tube	0 to +250 °C / briefly up to +300 °C	

Ordering data Fine pressure probe	Part no.
Fine pressure probe for testo 330 LL	0638 0330
Pressure set with flue draught probe, includes 2 x silicone hoses each with Ø 4mm and Ø6mm, 4mm and 6mm T-piece, connecting piece	0554 3150
Update CD (contains Firmware update for testo 330 and a test version of the PCanalysis software "easyheat")	0554 3351

## User-friendly, portable data management for flue gas analysis

### The testo easyheat and easyheat.mobile software package

The latest top technology in flue gas analysis: the testo 330 LL product line with extended sensor life not only communicates with PC but with also with your Pocket PC. Various software packages give the customer the option of adapting his testo 330 LL exactly to his communications needs.

Using easyheat PC software, customer data, sites and measurements which have already been taken, are easily managed on your PC at home.

easyheat.mobile Pocket PC software supports wireless communication with Windows Mobile instruments. In this way, wireless acceptance of measurement data to the mobile instrument is possible.

Data from the Pocket PC or directly from the analyser is printed on your IrDA printer.

#### System requirements:

#### easyheat PC software:

Microsoft Windows 98 operating system, ME 2000, from Service Package 3 up, or XP

#### easyheat.mobile Pocket PC software:

Pocket PC with IrDA interface and touchscreen, operating system from Windows Mobile 2003

#### Fast-action IrDA printer:

Please refer to the list of Pocket PCs tested and recommended by Testo at [www.testo.de/downloads/easyheat.mobile](http://www.testo.de/downloads/easyheat.mobile)



Accessories Ordering data	Part no.
USB connection cable, instrument to PC	0449 0047
BLUETOOTH® printer set with wireless Bluetooth interface, incl. 1 roll thermal paper, rechargeable battery and mains unit	0554 0553
Spare thermal paper for printer (6 rolls), permanent ink	0554 0568

Software	Part no.
Demo version easyheat and easyheat.mobile. Demo version of PC and Pocket PC software, 30 day test version	0554 1212
easyheat PC analysis software, shows measurement in form of diagrams, tables and manages customer data.	0554 3332
Full version easyheat and easyheat.mobile. Software package for PC and Pocket PC.	0554 1210

## Communication sets testo 330-1 LL and testo 330-2 LL

### The new testo 330-1 LL communication set mit Bluetooth®

- testo 330-1 LL flue gas analyser with rech. battery and calibration protocol
- Power pack 100-240 V for mains operation or battery recharging in analyser
- Modular flue gas probe, 300 mm immersion depth, ø 8 mm
- Combustion air temperature probe, 190 mm long
- Hose connection set for separate gas pressure measurement
- Bluetooth® printer with rechargeable battery
- Full version: easyheat and easyheat.mobile
- USB cable connecting analyser to PC
- Basic system case for analyser, probes and accessories

**Part no. 0563 3324 80**

### The new testo 330-2 LL communication set with Bluetooth®

- testo 330-2 LL flue gas analyser with rech. battery and calibration protocol
- Power pack 100-240 V for mains operation or battery recharging in analyser
- Modular flue gas probe, 300 mm immersion depth, ø 8 mm
- Combustion air temperature probe, 190 mm long
- Hose connection set for separate gas pressure measurement
- Bluetooth® printer with rechargeable battery
- Full version: easyheat and easyheat.mobile
- USB cable connecting analyser to PC
- Basic system case for analyser, probes and accessories

**Part no. 0563 3325 84**

### The new communication complete set testo 330-2 LL with Bluetooth® and smoke tester

- Exhaust gas analyzer testo 330-2 LL incl. battery and calibration protocol
- Smoke tester testo 308
- Mains unit 100-240 V for mains operation or charging the battery in the instrument
- Modular flue gas probe, immersion depth 300 mm, Ø 8 mm
- Combustion temperature probe, length 190 mm
- Hose connection set for separate gas pressure measurement
- Bluetooth® printer with rechargeable battery
- Full version easyheat and easyheat.mobile
- USB connection cable, instrument to PC
- Basic system case for instrument, probes and accessories

**Part no. 0563 3325 85**



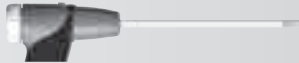





Illustration may differ from original!



## Accessories for testo 330-1/-2 LL

Instruments / Options / Upgrades	Part no.
testo 330-1 LL flue gas analyzer with long-life gas sensors, rechargeable battery and calibration protocol included	0632 3304
testo 330-2 LL flue gas analyser with long-life gas sensors and built-in draught and gas zeroing, rech. batt. and calibration protocol included	0632 3305
Option: Fine draught measurement, Resolution 0.1 Pa, measurement range to 100 Pa (instead of the standard draught measurement)	0440 3921
Option: NO sensor, meas. range 0 to 3000 ppm, 1 ppm resolution	0440 3922
Option: NOlow sensor, meas. range 0 to 300 ppm, 0.1 ppm resolution	0440 3931
Option: BLUETOOTH® module	0344 0011
Retrofit: NO sensor, meas. range 0 to 3000 ppm, 1 ppm resolution	0554 3922
Retrofit: NOlow sensor, meas. range 0 to 300 ppm, 0.1 ppm resolution	0554 3931
Upgrade testo 330-1 to testo 330-1 LL (only possible by Testo service!)	Part no.
Upgrade testo 330-1 to testo 330-1 LL consisting of:	
Option code upgrade testo 330-1 to testo 330-1 LL	0450 1100
Retrofit: O2 LL sensor	0554 3938
Retrofit: CO LL sensor	0554 3936
Upgrade testo 330-2 to testo 330-2 LL (only possible by Testo service!)	Part no.
Upgrade testo 330-2 to testo 330-2 LL consisting of:	
Option code upgrade testo 330-1 to testo 330-1 LL	0450 1100
Retrofit: O2 LL sensor	0554 3938
Retrofit: CO LL sensor	0554 3937
Accessories	Part no.
100-240 V AC / 6.3 V DC international mains unit for mains operation or battery charging in instrument	0554 1096
Spare rech. batt. w/ charging station	0554 1087
Li-ion battery pack	0515 0100
Testo fast printer with wireless infrared interface, 1 roll thermal paper and 4 AA batteries	0554 0549
BLUETOOTH® printer set with wireless Bluetooth interface, incl. 1 roll thermal paper, rechargeable battery and mains unit	0554 0553
Spare thermal paper for printer (6 rolls), permanent ink	0554 0568
Holster (SoftCase) for testo 335/testo 330 with belt	0516 0335
Barcode reader, to read in customer number on site	0554 0461
Adhesive pockets (50 off) for printout, paper barcode labels...	0554 0116
Smoke tester with oil, soot sheet, for measuring soot in flue gas	0554 0307
Hose connection set for separate gas pressure measurement	0554 1203
Differential temperature set consisting of 2 pipe clamp probes and adapter	0554 1204
Spare particle filter (10 off)	0554 3385
ISO calibration certificate/flue gas	0520 0003
Instrument cleaner (100 ml), for easy and fast removal of dirt from housing, display screen, keypad, probe handle and probe cable	0554 1207
Readout adapter for automatic furnaces	0554 1206
Software	Part no.
Demo version easyheat and easyheat.mobile.	0554 1212
easyheat PC analysis software, shows measurement in form of diagrams, tables and manages customer data.	0554 3332
Full version easyheat and easyheat.mobile. Software package for PC and Pocket PC.	0554 1210
USB connection cable, instrument to PC	0449 0047
Cases	Part no.
Basic system case for analyzer, probes and accessories	0516 3330
Basic system case with two levels for analyser, probes and additional accessories	0516 3331
Tools system case with tools section, without contents, attachable to basic system case	0516 0329
Versatile system case without sections, attachable to basic system case	0516 0331
Measurement case (leather) with drawers for instruments and accessories	0516 0303

## Accessories for testo 330-1/-2 LL

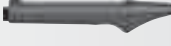
Spare gas sensors		Part no.			
O <sub>2</sub> sensor for testo 330-1 LL/-2 LL		0390 0061			
NOlow sensor 0 to 300 ppm for testo 330-1 LL/-2 LL		0390 0094			
NO sensor 0-3000 ppm for testo 330-1 LL/-2 LL		0390 0074			
CO sensor (without H <sub>2</sub> compensation) for testo 330-1 LL		0390 0110			
CO sensor (H <sub>2</sub> compensated) for testo 330-2 LL		0390 0090			
Retrofit: NOlow sensor, meas. range 0 to 300 ppm, 0.1 ppm resolution for testo 330-1 LL/-2 LL		0554 3931			
Probes		Part no.			
Flue gas probe, 180 mm long, Ø 8 mm, Tmax 500 °C, TÜV approval	 <p>Modular flue gas probes, available in 2 lengths, incl. probe stop for positioning, NiCr-Ni thermocouple, 2.2 m hose and particle filter</p>	0600 9760			
Flue gas probe, 300 mm long, Ø 8 mm, Tmax 500 °C, TÜV approval		0600 9761			
Flue gas probe, 180 mm long, Ø 6 mm, Tmax 500 °C		0600 9762			
Flue gas probe, 300 mm long, Ø 6 mm, Tmax 500 °C		0600 9763			
Flexible flue gas probe, 330 mm long, Tmax. 180 °C, short-term 200 °C, bending radius max. 90° for measuring at inaccessible points		0600 9764			
Probe accessories		Part no.			
Probe shaft, 180 mm long, Ø 8 mm, Tmax 500 °C		0554 9760			
Probe shaft, 180 mm long, Ø 6 mm, Tmax 500 °C		0554 9762			
Probe shaft, 300 mm long, Ø 8 mm, Tmax 500 °C		0554 9761			
Probe shaft, 335 mm long, with probe stop, Ø 8 mm, Tmax 1000 °C		0554 8764			
Probe shaft, 700 mm long, with probe stop, Ø 8 mm, Tmax 1000 °C		0554 8765			
Flexible probe shaft, 330 mm long, Ø 10 mm, Tmax 180 °C		0554 9764			
Multi-hole probe shaft, 180 mm long, Ø 8 mm, for mean CO calculation		0554 5763			
Multi-hole probe shaft, 300 mm long, Ø 8 mm, for mean CO calculation		0554 5762			
Hose extension, 2.8 m, extension cable for probe and analyser		0554 1202			
6 mm, probe stop, steel, with spring clamp and handle, Tmax 500 °C		0554 3329			
8 mm probe stop, steel, with spring clamp and handle, Tmax 500 °C		0554 3330			
Additional probes		Meas. range	Accuracy	Part no.	
Dual wall clearance probe for O <sub>2</sub> supply air measurement				0632 1260	
Gas leak probe		0 to +10000 ppm CH <sub>4</sub> / C <sub>2</sub> H <sub>6</sub>		0632 3330	
Ambient CO probe		0 to +500 ppm CO	±5% of mv (+100.1 to +500 ppm CO) ±5 ppm CO (0 to +100 ppm CO)	0632 3331	
Ambient CO <sub>2</sub> probe		0 ... +1 Vol. % CO <sub>2</sub> 0 ... +10000 ppm CO <sub>2</sub>	±(50 ppm CO <sub>2</sub> ±2% of mv)(0 to +5000 ppm CO <sub>2</sub> ) ±(100 ppm CO <sub>2</sub> ±3% of mv)(+5001 to +10000 ppm CO <sub>2</sub> )	0632 1240	
Connection cable				0430 0143	
Combustion air temperature probe		Part no.			
Combustion air temperature probe, immersion depth 300 mm		0600 9791			
Combustion air temperature probe, immersion depth 190 mm		0600 9787			
Combustion air temperature probe, immersion depth 60 mm		0600 9797			
Additional temperature probes		Meas. range	Accuracy	t <sub>99</sub>	Part no.
Mini ambient air probe					0600 3692
Pipe wrap probe for pipes with diameter of up to 2", for flow/return temp. meas. in hydronic systems		-60 to +130 °C	Class 2	5 s	0600 4593 Conn.: Fixed cable
Quick-action surface probe	 150 mm Ø 10 mm	-200 to +300 °C	Class 2	3 s	0604 0194 Conn.: Plug-in head, connection cable 0430 0143 or 0430 0145 required
Connection cable					0430 0143

## testo 350-S, portable flue gas analysis system

### testo 350-S

testo 350 is a versatile portable measuring system. The measuring system consists in principle of a Control Unit, a flue gas analyser and a flue gas probe, depending on the wishes and requirements of the customer.

The testo 350-S flue gas analyser is equipped with a sensor for  $O_2$  as standard. In addition, one sensor must be fitted, or up to 5 additional sensors can be fitted. The following gas sensors are available for this purpose:  $NO_2$ ,  $SO_2$ ,  $NO$ ,  $NO_{low}$ ,  $CO$ ,  $CO_{low}$ ,  $H_2S$ ,  $HC$  or  $CO_2$  by infrared sensor.

Temperature and differential pressure are also measured as well as the usual parameters such as  $CO_2$  and  $qA$ .

- Max. 6 electrochemical gas sensors
- Built-in rechargeable battery for battery operation
- Measurement data memory (250,000 readings)
- Testo databus connection

**NEW!**

Now with

 **Bluetooth**  
Wireless transmission



Sensors can be changed quickly and easily by the user on site



Condensate trap – Built-in Peltier gas preparation unit with hose pump for disposing of condensate for long-term measurements lasting several hours



Infrared (NDIR) sensor for direct  $CO_2$  measurement



Sensor heating element – protects from damage caused by condensate and increases sensor reaction times at low ambient temperatures



## Flexible flue gas analysis system testo 350-S

testo 350-S control unit	Part no.
Control unit displays measurement data and controls measurement system, built-in printer, connection for Testo data bus and terminal plug included	0563 0369
<b>Further options only for Control Unit testo 350-S</b>	
<b>NEW!</b> BLUETOOTH® wireless transmission	0440 0550
Spare thermal paper for printer (6 rolls)	0554 0569
Testo rechargeable battery pack NiMH for control unit, logger	0515 0097
<b>testo 350-S flue gas analyser box</b>	
<b>Part no.</b>	
testo 350-S flue gas analyser, equipped with: O <sub>2</sub> , differential pressure measurement, 2 temperature probe sockets, testo data bus connection, built-in rechargeable battery, data logger, can be upgraded to max. 6 sensors (with NO, NO <sub>2</sub> , CO, H <sub>2</sub> S, HC, SO <sub>2</sub> , CO <sub>2</sub> NDIR)	0563 0368
<b>A second gas sensor must be installed in testo 350-S, otherwise the instrument is unable to function. Up to 5 additional sensors can be fitted.</b>	
Option: COlow sensor	0440 3936
Option: CO sensor	0440 3988
Option: CO2 sensor (infrared meas. principle, absolute pressure meas. and CO2 absorption filter with refill pack incl.)	0440 0417
Option: HC sensor (nonburned hydrocarbons)	0440 3929
Option: H2S sensor	0440 3930
Option: NO sensor	0440 3935
Option: NOlow sensor	0440 3928
Option: NO2 sensor	0440 3926
Option: SO2 sensor	0440 3927
<b>NEW!</b> BLUETOOTH® wireless transmission	0440 0550
Option: Peltier gas preparation with hose pump to empty condensate automatically	0440 0355
Fresh air valve for long-term measurement (measurement range extension with dilution factor 5 for all sensors included)	0440 0557
Measuring range extension for CO sensor (dilution), built into analyser box, selectable dilution factors: 0, 2, 5, 10, 20, 40	0440 0555
Event trigger socket, for starting and stopping measurement externally, built into analyser box	0440 3932
Special gas pump for long-term measurements with extended warranty (For continuous measurements >2 h measurement time, the option Peltier gas preparation 0440 0355 is additionally recommended).	0440 0378
<b>Accessories</b>	
<b>Part no.</b>	
Mains unit 230 V / 8 V / 1 A, for instrument (European plug), for mains operation and battery recharging	0554 1084
Cable, coiled, 2m, connects control unit and analysis box	0449 0052
Hose connection set for gas pressure measurement on heating systems, incl. silicone hoses and T-pieces	0554 0315
Spare thermal paper for printer (6 rolls)	0554 0569
Instrument cleaner (100 ml)	0554 1207
Carrying belt set for analyser box and control unit	0554 0434
Measurement case (leather) with drawers for analysers and accessories	0516 0307
"easyEmission" software for testo 350-S/-XL, RS232 cable for connecting instrument to PC included	0554 3335

### Country permits BLUETOOTH® wireless transmission for control unit testo 350-S and the flue gas analyzers testo 350-S/-XL

The BLUETOOTH® radio module used by Testo is permitted for the following countries and may only be used in those countries, i.e. the BLUETOOTH® wireless transmission may not be used in any other country!

#### Europe including all EU member states

Austria, Belgium, Bulgaria, Czech Republic, Cyprus, Denmark, Estonia, Finland, France, Germany, Great Britain, Greece, Hungary, Ireland, Italy, Latvia, Luxembourg, Malta, Netherlands, Poland, Portugal, Romania, Sweden, Slovakia, Slovenia, Spain and Turkey

#### European countries (EFTA)

Iceland, Liechtenstein, Norway, Switzerland

#### Non-European countries

Canada, USA, Japan, Ukraine, Australia, Colombia and El Salvador

### Recommended Set: testo 350-S, Basic set for installation and customer service

Control unit displays measurement data and controls measurement system, built-in printer, connection for Testo data bus and terminal plug included	0563 0369
testo 350-S flue gas analyser, equipped with: O <sub>2</sub> , differential pressure measurement, 2 temperature probe sockets, testo data bus connection, built-in rechargeable battery, data logger, can be upgraded to max. 6 sensors (with NO, NO <sub>2</sub> , CO, H <sub>2</sub> S, HC, SO <sub>2</sub> , CO <sub>2</sub> NDIR)	0563 0368
Option: CO sensor	0440 3988
Cable, coiled, 2m, connects control unit and analysis box	0449 0052
Basic flue gas probe, 335 mm immersion depth, with probe stop, NiCr-Ni (Ti) T/C, probe shaft: stainless steel 1.4361 (Tmax 500°C), 2.2 m hose, robust plug-in coupling	0600 7451
Smoke tester with oil, soot sheet, for measuring soot in flue gas	0554 0307
Combustion air temperature probe, immersion depth 60 mm	0600 9797
Transport case for analyser, probes and accessories	0516 0351

### Recommended Set: testo 350-S, Set for fast emission monitoring on industrial burners (O<sub>2</sub>, CO, NO)

Control unit displays measurement data and controls measurement system, built-in printer, connection for Testo data bus and terminal plug included	0563 0369
testo 350-S flue gas analyser, equipped with: O <sub>2</sub> , differential pressure measurement, 2 temperature probe sockets, testo data bus connection, built-in rechargeable battery, data logger, can be upgraded to max. 6 sensors (with NO, NO <sub>2</sub> , CO, H <sub>2</sub> S, HC, SO <sub>2</sub> , CO <sub>2</sub> NDIR)	0563 0368
Option: NO sensor	0440 3935
Option: CO sensor	0440 3988
Basic flue gas probe, 335 mm immersion depth, with probe stop, NiCr-Ni (Ti) T/C, probe shaft: stainless steel 1.4361 (Tmax 500°C), 2.2 m hose, robust plug-in coupling	0600 7451
Heat-resistant probe shaft (material: stainless steel 1.4841) with heat-resistant plate, 335 mm long, Tmax + 1000 °C	0440 7437
Connection cable, 2 m, for Testo data bus	0449 0042
Protective cover for analyser box (can also be used with wall holder)	0554 0199
Carrying belt set for analyser box and control unit	0554 0434
Transport case for analyser, probes and accessories	0516 0351
Spare particle filter, pack of 20	0554 3381
Spare thermal paper for printer (6 rolls)	0554 0569

### Technical data

Maximum no. of gas sensors	6
O <sub>2</sub> 0 – 25 Vol.	■
CO (H2) 0 – 10,000 ppm	○
CO <sub>low</sub> (H2) 0 – 500 ppm	○
NO 0 – 3,000 ppm (0.1 ppm resolution)	○
NO <sub>low</sub> 0 – 300 ppm (0.1 ppm resolution)	○
NO <sub>2</sub> 0 – 500 ppm (0.1 ppm resolution)	○
SO <sub>2</sub> 0 – 5,000 ppm	○
HC 0 – 4 Vol. % (0.001 % resolution)	○
H <sub>2</sub> S 0 – 300 ppm (0.1 ppm resolution)	○
CO <sub>2</sub> (NDIR) 0 – 50 Vol. %	○
Built-in gas preparation unit (is recommended with high humidity levels in flue gas and during long-term measurements >2 hrs measuring time)	○
Automatic fresh air rinse with valve (incl. measurement range extension with dilution factor 5 for all sensors)	○
Measurement range extension for CO sensor (with selectable dilution factors)	○
CO sensor switch-off via adjustable switch-off threshold	■
Trigger input – stops and starts measurement externally	○
Differential pressure measurement (-40 to +40 hPa / -200 to +200 hPa)	■
Built-in rechargeable battery	■
2 temperature probe sockets (Type K NiCr-Ni)	■
Data logger (250,000 readings)	■
Testo data bus connection	■
BLUETOOTH® wireless transmission	○

■ = Standard

○ = upgrade option

## Probes and Accessories

Standard flue gas sampling probe, 335 mm long	Part no.
<b>Basic flue gas probe, 335 mm immersion depth, with probe stop, NiCr-Ni (Ti) T/C, probe shaft: stainless steel 1.4361 (Tmax 500°C), 2.2 m hose, robust plug-in coupling</b>	0600 7451
<b>Options:</b>	
Heat-resistant probe shaft with pre-filter, Tmax. +1000 °C, 335 mm long, for dusty flue gases, 3 µm pore size, probe shaft: stainless steel 1.4841	0440 7435
<b>or:</b>	
Heat-resistant probe shaft (material: stainless steel 1.4841) with heat-resistant plate, 335 mm long, Tmax + 1000 °C	0440 7437
Hose, 5 m long	0440 7443
Special hose for NO <sub>2</sub> /SO <sub>2</sub> measurements, 2.2 m long*	0440 7442
Special hose for NO <sub>2</sub> /SO <sub>2</sub> measurements, 5 m long*	0440 7445
Standard gas sampling probe, 700 mm long	Part no.
<b>Basic flue gas probe, 700 mm immersion depth, with probe stop, NiCr-Ni (Ti) T/C, probe shaft: stainless steel 1.4361 (Tmax 500°C), 2.2 m hose, robust plug-in coupling</b>	0600 7452
<b>Options:</b>	
Heat-resistant probe shaft with pre-filter, Tmax. +1000°C, 700 mm long, for dusty flue gases, 3 µm pore size, probe shaft: stainless steel 1.4841	0440 7436
<b>or:</b>	
Heat-resistant probe shaft (material: stainless steel 1.4841) with heat-resistant plate, 700 mm long, Tmax +1000 °C	0440 7438
Hose, 5 m long	0440 7444
Special hose for NO <sub>2</sub> /SO <sub>2</sub> measurements, 2.2 m long*	0440 7442
Special hose for NO <sub>2</sub> /SO <sub>2</sub> measurements, 5 m long*	0440 7446
Accessories for exterior shaft with filter	Part no.
Spare sintered filter (2 off)	0554 3372
Probes	Part no.
TÜV approved flue gas probe, 335 mm immersion depth, up to +500°C, corresponding to the latest instrument test guidelines, also for atmospheric gas systems, 2.2 m hose	0600 9557

\* Use outer shaft with filter for dusty flue gases.

## Cases

### Case system

- The attachable case system especially for contractors makes it easy to transport all your equipment
- The system case, particularly robust, made of ABS plastic, with foam inserts
- Unlimited extension possibilities with the Testo case system



Tools system case with tools section, without contents, attachable to basic system case

Part no. 0516 0329



Versatile system case without sections, attachable to basic system case

Part no. 0516 0331

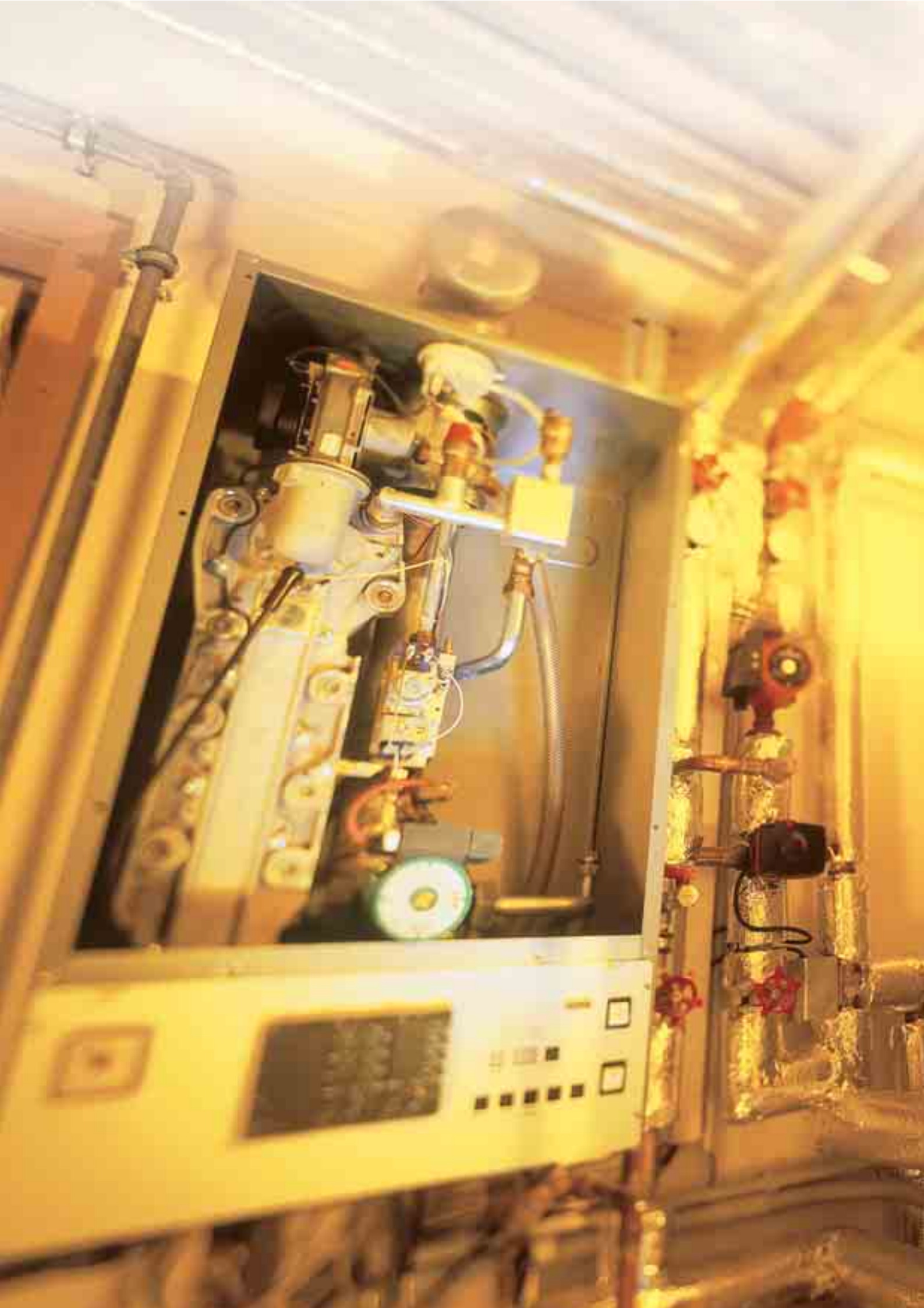

## Surface temperature measurement – Spot-on

### testo 905-T2

The testo 905-T2 surface thermometer measures surface temperatures up to +500 °C quickly and reliably. The sprung, wide thermocouple measurement head guarantees fast reaction times and high accuracy.

- Very fast reaction time
- High accuracy
- Sprung thermocouple cross-band adapts to any surface
- Easy readout of readings due to rotatable display
- Very simple to operate
- Auto-Off function

#### testo 905-T2

testo 905-T2: surface thermometer with cross-band probe, incl. attachment clip, battery

Part no. 0560 9056

#### Technical data

Meas. range	-50 to +350 °C Short-term to +500 °C
Accuracy ±1 digit	±(1 °C ±1% of mv)
Resolution	0.1 °C
Oper. temp.	0 to +50 °C
Storage temp.	-20 to +70 °C
Battery life	1000 h

With a flexible joint

testo 905-T2: sprung thermocouple cross-band Ø 12 mm adapts to any surface

Measuring surface temperature, e.g. on a radiator

## Differential temperature measurement – At a glance

### testo 922

The differential thermometer measures the temperature readings of 2 TC probes and shows them simultaneously in the display. An audible alarm sounds if limit values are exceeded. Current measurement data as well as max/min data can be printed on site on the Testo fast printer.

- Displays differential temperature
- Continuous display of max/min values
- Hold button to freeze reading
- TopSafe, indestructible case, protects from dirt and impact (option)
- Display light

#### testo 922

testo 922, 2 channel temperature measuring instrument T/C Type K, connection of an optional radio probe, with battery and calibration protocol

Part no. 0560 9221

#### Technical data

Meas. range	-50 to +1000 °C
Probe type	Type K (NiCr-Ni)
Dimensions	182 x 64 x 40 mm
Weight	171 g

#### Accessories Ordering data

Accessories Ordering data	Part no.
TopSafe, protects from impact and dirt	0516 0222
Testo fast printer with wireless infrared interface, 1 roll thermal paper and 4 AA batteries	0554 0549
Transport case for measuring instrument, 3 probes and accessories (430 x 310 x 85 mm)	0516 0200

#### Suitable probes at a glance

Suitable probes at a glance	Part no.
Pipe wrap probe for pipe diameter 5 to 65 mm, with exchangeable measuring head. Meas. range short-term to +280°C, TC Type K	0602 4592
Waterproof immersion/penetration probe, TC Type K	0602 1293

Cyclical printing of readings, e.g. once a minute

Differential temperature (flow/return) measurement

## Monitors ambient temperature – Efficiently

### testo 174

The testo 174 mini data logger can measure room temperatures over longer periods of time which means it can be used to monitor the control behaviour of a thermostat valve. The current reading is shown in the display. The following can be called up: Stored minimum and maximum value, limit values and battery life.

- Accurate, efficient temperature logging with up to 3900 readings
- Alarm display if user defined maximum/minimum values are exceeded
- Software for data export, data analysis and parameterisation (optional)
- Data secure even if battery is spent



Large display



Data transfer to PC or notebook via interface (optional)



Logging room temperature with immediate alarm display if limits are exceeded

Technical data	
Meas. range	-30 to +70 °C
Data memory	3900 readings
Measuring rate	1 min ... 4 h
Battery life	500 days (typical)
Analysis software	MS Windows 95b / 98 / ME / 2000 / XP / Vista
Dimensions	55 x 35 x 14 mm
Weight	24 g

#### testo 174, Starter Set

Mini temperature data logger, 1 channel, ComSoft 4 Basic, wall holder, lock, interface incl. PC connection cable, battery

Part no. 0563 1742

#### testo 174

Mini temperature data logger, 1 channel, incl. wall holder, lock and battery

Part no. 0563 1741

#### testo 174, USB Set

Mini temperature data logger, 1 channel, ComSoft 4 Basic, wall holder, USB interface with PC connection cable and battery

Part no. 0563 1743

## Monitors temperature – Long-term and uninterrupted

### testo 175-T3

The 175-T3 temperature data logger logs temperature at 2 different points simultaneously over a period of several days, weeks or months. You can, for example, check the temperature spread between the flow and return of a heating system over a longer period of time.

- Temperature logging with up to 16000 readings
- Alarm display when user defined maximum/minimum values have been exceeded
- Software for data analysis and parameterisation (optional)

Accessories Ordering data	Part no.
Fast testo 575 printer, incl. 1 roll of thermal paper and batteries	0554 1775
Spare thermal paper for printer (6 rolls), permanent ink, measurement data documentation legible for up to 10 years	0554 0568
Lock for wall holder for testo 175/177 data loggers	0554 1755
ComSoft 4 - Basic Set with RS232 interface for testo 175	0554 1759

Suitable probes at a glance	Part no.
Pipe wrap probe for pipe diameter 5 to 65 mm, with exchangeable measuring head. Meas. range short-term to +280°C, TC Type K	0602 4592

Technical data	
Meas. range	-50 to +400 °C -50 to +1000 °C
Data memory	16000
Measuring rate	10 s to 24 h
Battery life	> 2.5 years*
Analysis software	MS Windows 95b / 98 / ME / 2000 / XP / Vista
Dimensions	82 x 52 x 30 mm
Weight	90 g

\* At a measuring cycle of 15 min (-10 to +50°C)



Data is sent to PC or notebook via attachable interface (optional)



Inspects flow/return temperature

#### testo 175-T3

testo 175-T3, temperature data logger, 2 channels, with 2 probe inputs, wall holder and calibration protocol; calibration certificates (ISO/DKD) must be ordered separately

Part no. 0563 1756



## testo 875 and testo 881 for professional building thermography

The testo 875 and testo 881 thermal imagers carry out fast and efficient tests on heating and air conditioning/ventilation systems. testo 875 and testo 881 support you in finding the cause when leaks are detected in floor heating systems or other difficult to access pipe systems. Defective installations can be accurately recognised by the thermal imager making it possible to quickly carry out damage control and specific maintenance.

testo 875 and testo 881 thermal imagers detect energy losses quickly and without damage. Weak points such as heat bridges as well as construction and building defects on the building's facade are displayed immediately on Testo's thermal imager.

Even the smallest temperature differences can be identified with the high temperature resolution of the Testo thermal imagers. Exchangeable telephoto lenses ensure top flexibility and that, depending on the application, the right image section can always be seen in the camera's display. The digital camera which is also built-in makes documentation easy.

Via the manual input of ambient temperature, air humidity and dewpoint in the room, testo 875 and testo 881 visualize mould risk spots in the thermal image at a glance. This important data helps improve indoor climate and prevent dangerous allergenic mould growth, or minimize the risk of mould – even in the hidden corners and niches of a house. With the Testo thermal imagers you are hot on the trail of burst pipes and can accurately check heating systems and installations.

### Professional analysis software

Clearly structured and user-friendly PC software allows comprehensive analysis and evaluation of thermograms. You can now process, analyze and document several parallel infrared images in a report together with their respective real images. Especially for the purpose of examining building shells for heat bridges, the software offers report templates, with which reports compliant with DIN EN 13187 can be created. In order to achieve precise analysis results, it is possible to correct the thermal image according to the different emissivities of the various materials by area, right up to individual pixels. Pro software is included with all Testo thermal imagers.



Just take it with you in the Soft-Case



Simply change the lens



Easy operation

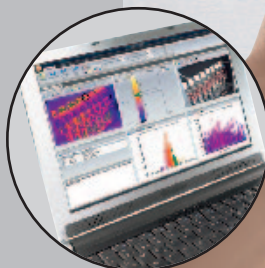

Easy and precise analysis



## The 4 most important advantages of the thermal imager testo 875

### Good image quality

With the temperature resolution of  $<80$  mK, even the smallest temperature differences are displayed.



### Integrated digital camera

The testo 875 with integrated digital camera links real and infrared images for your fast and easy documentation of the measurement.



### Automatic Hot-Cold-Spot recognition

Critical temperature statuses are displayed using automatic Hot-Cold-Spot recognition. This guarantees uninterrupted error localization on site. Auto Hot/Cold Spot Recognition facilitates analysis and documentation when evaluating the details later on a PC.

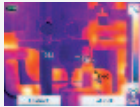

### Detection of mould-risk spots

Via the manual input of ambient temperature, air humidity and dewpoint in the room, the testo 875 visualizes mould-risk spots in the thermal image at a glance.

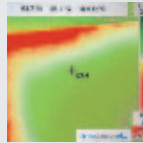

#### testo 875-1

Part no. 0560 8751

#### testo 875-2

Part no. 0560 8752

#### testo 875-2 Set

Part no. 0563 8752

## The 5 most important advantages of the thermal imager testo 881

### Highest image quality

With a thermal resolution of  $<50$  mK, the testo 881 delivers high definition images which emphasize and visualize even the smallest temperature differences.



### Isotherm function

With the optical coloured alarm, critical temperature areas on the measurement object are marked immediately in colour.

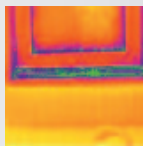

### Detection of mould risk spots

Via the manual input of ambient temperature, air humidity and dewpoint in the room, the testo 875 and testo 881 visualize mould risk spots in the thermal image at a glance.

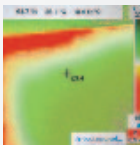

### Voice recording

The practical headset and the integrated speech recording function simplify the documentation of the measurement results. Every image can be commented directly on site. This valuable information is stored together with the thermal image.

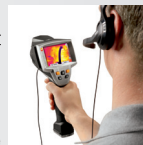

### Integrated digital camera with power LEDs

In addition to infrared recording, the testo 881 creates a parallel real image of the measurement site with the integrated digital camera. The power LEDs guarantee optimum illumination of dark areas when recording real images.



#### testo 881-1

Part no. 0563 0881 V1

#### testo 881-2

Part no. 0563 0881 V2

#### testo 881-3

Part no. 0563 0881 V3

#### testo 881-3 Set

Part no. 0563 0881 V4



## Ordering overview testo 875

### testo 875-1

- NETD < 80 mK
- High quality standard lens 32° x 23°
- Auto Hot/Cold Spot Recognition
- Manual focus
- Temperature range -20 to +280 °C

Part no. 0560 8751

### testo 875-2

- NETD < 80 mK
- High quality standard lens 32° x 23°
- Integrated digital camera
- Display of surface moisture distribution
- Auto Hot/Cold Spot Recognition
- Manual focus
- Temperature range -20 to +280°C
- Telephoto lens (optional)

Part no. 0560 8752

### testo 875-2 Set

- NETD < 80 mK
- High quality standard lens 32° x 23°
- Integrated digital camera
- Display of surface moisture distribution
- Auto Hot/Cold Spot Recognition
- Manual focus
- Temperature range -20 to +280 °C

In addition to the equipment of testo 875-2, the set also includes:

- Telephoto lens 9° x 7°
- Protective lens
- Additional battery
- Charger
- Sun Shield

Part no. 0563 8752



## Ordering overview testo 881

### testo 881-1

- NETD < 50 mK
- High quality standard lens 32° x 23°
- Integrated digital camera
- Auto Hot/Cold Spot Recognition
- Manual focus
- Temperature range -20 to +350 °C
- 33 Hz (inside the EU, outside 9 Hz)

Part no. 0563 0881 V1

### testo 881-2

- NETD < 50 mK
- High quality standard lens 32° x 23°
- Telephoto lens (optional)
- Auto Hot/Cold Spot Recognition
- Display of surface moisture distribution
- Manual focus
- Temperature range -20 to +350°C
- 33 Hz (inside the EU, outside 9 Hz)
- Headset for speech recording
- Lens protection glass
- Isotherm display in instrument
- Min-/Max on Area calculation

Part no. 0563 0881 V2

### testo 881-3

- NETD < 50 mK
- High quality standard lens 32° x 23°
- Telephoto lens (optional)
- Built-in digital camera with power LEDs
- Display of surface moisture distribution
- Auto Hot/Cold Spot Recognition
- Dynamic motor focus
- Temperature range -20 to +350°C
- 33 Hz (inside the EU, outside 9 Hz)
- Headset for speech recording
- Lens protection glass
- Isotherm display in instrument
- Min-/Max on Area calculation
- High temperature measurement (optional)

Part no. 0563 0881 V3

### testo 881-3 Set

- NETD < 50 mK
- High quality standard lens 32° x 23°
- Built-in digital camera with power LEDs
- Display of surface moisture distribution
- Auto Hot/Cold Spot Recognition
- Dynamic motor focus
- Temperature range -20 to +350°C
- 33 Hz (inside the EU, outside 9 Hz)
- Headset for speech recording
- Lens protection glass
- Isotherm display in instrument
- Min-/Max on Area calculation
- High temperature measurement (optional)

In addition to the equipment of testo 881-3, the set also includes:

- Telephoto lens 9° x 7°
- Additional battery
- Charger
- Soft-Case

Part no. 0563 0881 V4



		testo 881-1	testo 881-2	testo 881-3	testo 881-3 Set
	Part no.	0563 0881 V1	0563 0881 V2	0563 0881 V3	0563 0881 V4
<b>Additionally in the case:</b>					
Lens protection glass	C1	●	●	●	●
Telephoto lens	A1	–	●	●	●
Additional battery	D1	●	●	●	●
Fast battery charger	E1	●	●	●	●
Soft-Case	H1	●	●	●	●
High temperature measurement	G1	–	–	●	●

● Standard

● Optional

– Not available

All imagers are delivered in a robust case incl. pro software, SD card, USB cable, mains unit, Li ion rechargeable battery and tripod adapter.



## Accessories for testo 875 and testo 881 thermal imagers

### Aluminium tripod

Professional, extremely light and stable aluminium tripod with Quick-Release legs and 3-way tripod head



Part no. 0554 8804

### Lens protection glass

Special Germanium protective glass for optimum protection of the lens from dust and scratching



Part no. 0554 8805

### Additional battery

Additional lithium ion rechargeable battery for extending the operating time



Part no. 0554 8802

### Fast battery charger

Desktop charging station for two rechargeable batteries for the optimization of charging time



Part no. 0554 8801

### Sun Shield

Special sun shield for the display of testo 881 and testo 875 in bright surroundings



Part no. 0554 8806

### Soft-Case

Practical carrying option for testo 881 and testo 875 (incl. shoulder strap)



Part no. 0554 8814

### Additional accessories

### Part no.

Retrofit telephoto lens  
(for testo 881-2 and -3 and testo 875-2 only); please contact our Service.

Retrofit high temperature measurement  
(for testo 881-3 only); Please contact our Service.

Adhesive tape, e.g. for bare surfaces (roll, L.: 10 m, W.: 25 mm), E = 0.95, temperature resistant to +250 °C

0554 0051

ISO calibration certificates for testo 875, testo 881  
Calibration points at 0 °C, 25 °C, 50 °C in measuring range -20 °C to 100 °C

0520 0489

ISO calibration certificates for testo 881  
Calibration points at 0 °C, 100 °C, 200 °C in measuring range 0 °C to 350 °C

0520 0490

ISO calibration certificates for testo 875, testo 881  
Freely selectable calibration points in the range -18 °C to 250 °C

0520 0495

## Technical data for testo 875 and testo 881 thermal imagers

	testo 875-1	testo 875-2	testo 881-1	testo 881-2	testo 881-3
<b>Infrared image output</b>					
Detector type	FPA 160 x 120 pixels, a.Si		FPA 160 x 120 pixels, a.Si		
Thermal sensitivity (NETD)	< 80 mK at +30 °C		< 50 mK at +30 °C		
Field of vision/min. focusing distance	32° x 23° / 0.1 m (standard lens), 9° x 7° / 0.5 m (telephoto lens)		32° x 23° / 0.1 m (standard lens), 9° x 7° / 0.5 m (telephoto lens)		
Geometric resolution (IFOV)	3.3 mrad (standard lens), 1.0 mrad (telephoto lens)		3.3 mrad (standard lens), 1.0 mrad (telephoto lens)		
Image refresh rate	9 Hz		33 Hz for EU, otherwise 9 Hz		
Focus	manual		manual	manual and motor focus	
Spectral range	8 to 14 µm		8 to 14 µm		
<b>Visual image output</b>					
Field of vision/min. focusing distance	-	33° x 25° / 0.4 m	33° x 25° / 0.4 m	-	33° x 25° / 0.4 m
Image size	-	640 x 480 pixels	640 x 480 pixels	-	640 x 480 pixels
<b>Image presentation</b>					
Image display	3.5" LCD with 320 x 240 pixels		3.5" LCD with 320 x 240 pixels		
Display options	IR image only	IR image only / real image only/ IR and real image	IR image only / real image only/ IR and real image	IR image only	IR image only / real image only/ IR and real image
Video output	USB 2.0		USB 2.0		
Colour palettes	4 options (iron, rainbow, blue-red, shades of grey)		9 options (iron, rainbow, cold-hot, blue-red, grey, inverted grey, sepia, Testo, iron HT)		
<b>Measurement</b>					
Temperature range	-20 °C to +100°C / 0 °to +280 °C (switchable)		-20 °C to +100°C / 0 °to +350 °C (switchable)		
High temperature measurement (optional)	-		-	+350 °C to +550 °C	
Accuracy	±2 °C, ±2% of mv (-20 °C to +280 °C)		±2 °C, ±2% of mv (-20 °C to +350 °C)		±3% of mv (+350 °C to +550 °C)
Minimum measurement spot diameter	10 mm at 1 m (standard lens), 3 mm at 1 m (telephoto lens)		10 mm at 1 m (standard lens), 3 mm at 1 m (telephoto lens)		
Setting emissivity	0,01 to 1		0,01 to 1		
Reflected temperature compensation	manual		manual		
<b>Imager equipment</b>					
Digital camera	-	yes	yes	-	yes
Power LEDs	-	-	-	-	yes
Motor focus	-	-	-	-	yes
Standard lens (32° x 23°)	yes		yes		
Telephoto lens (9° x 7°)	-	optional	-	optional	
Laser sighting	-	-	yes (laser classification 635 nm, Class 2 )		
Speech recording	-	-	-	yes (using headset)	
Display of surface moisture distribution	-	yes (using manual input)	-	yes (using manual input)	
Measuring functions	Centre point	Standard measurement (1-point)	Standard measurement (1-point)		
	Hot/Cold Spot Recognition		Hot/Cold Spot Recognition		
	-	-	Two-point measurement		
	-	-	-	Isotherms	
	-	-	-	Min-/Max on Area	
<b>Image storage</b>					
File format	.bmt; export option in .bmp, .jpg, .csv		.bmt; export option in .bmp, .jpg, .csv		
Removable memory	SD card 2GB (approx. 1,000 images)		SD card 2GB (approx. 1,000 images)		
<b>Power supply</b>					
Battery type	Fast-charging, Li-ion battery can be changed on-site		Fast-charging, Li-ion battery can be changed on-site		
Operating time	4 hours		4 hours		
Charging options	In instrument/in charging station (optional)		In instrument/in charging station (optional)		
Mains operation	yes		yes		
<b>Ambient conditions</b>					
Operating temperature range	-15 °C to +40 °C		-15 °C to +40 °C		
Storage temperature range	-30 °C to +60 °C		-30 °C to +60 °C		
Air humidity	20% to 80% non-condensing		20% to 80% non-condensing		
Housing protection class	IP54		IP54		
Vibration (IEC 68-2-6)	2G		2G		
<b>Physical features</b>					
Weight	Approx. 900 g		Approx. 900 g		
Dimensions (L x W x H)	152 x 108 x 262 mm		152 x 108 x 262 mm		
Tripod mounting	yes		yes		
Housing	ABS		ABS		
<b>PC software</b>					
System requirements	Windows XP (Service Pack 2) Windows Vista, interface USB 2.0		Windows XP (Service Pack 2) Windows Vista, interface USB 2.0		
<b>Norms, tests, warranty</b>					
EU Directive	2004 / 108 / EC		2004 / 108 / EC		
Warranty	2 years		2 years		



## testo 845 – Infrared measurement engineering for temperature with built-in humidity module

The testo 845 is a milestone in non-contact temperature measurement. For the first time, surface temperatures with smallest diameters can be measured accurately at short and long distances. The switchable optics for far-field and close focus measurement make this possible.

testo 845 is equipped with an optical resolution of 75:1 for far-field measurements. Surface temperatures can be measured accurately even at great distances from the object to be measured. At a distance of 1.2 metres from the object to be measured, the measuring spot diameter is only 16 mm. A cross laser marks the measuring spot exactly during measurement. Incorrect measurements are eliminated - you always know exactly where you are measuring.

The close focus optics allow the measurement of temperatures on the smallest surfaces with a diameter of just 1 mm and a distance of 70 mm! Two lasers mark the measuring spot exactly.

- Switchable optics for far-field measurements (75:1) and close focus (1 mm, 70 mm distance)
- Especially bright cross laser sighting for indicating the actual measuring point
- Reference accuracy  $\pm 0.75$  °C with super-fast measurement technology (scanning 100 ms)
- Backlit display (3-line), shows °C, min./max. values, alarm limit values and emissivity; in addition display with humidity module: %RH, °Ctd
- Optical and audible alarm when limit values are exceeded
- Instrument memory for 90 measurement protocols
- PC software for archiving and documenting measurement data (included in delivery)
- Tripod fitting for online measurement via USB cable (included in delivery)



Switchable optics 1:  
far field 75:1 (16 mm,  
1200 mm distance) with  
cross-laser sighting



Switchable optics 2:  
Near field close focus (1  
mm, 70 mm distance)  
with 2 point laser  
sighting



testo 845 with additional  
humidity module for  
measuring ambient air  
humidity and  
determining dew  
point difference



Fast documentation  
thanks to on-site printout



# Infrared Thermometer with Switchable Optics (far-field/close focus)

## testo 845



testo 845, infrared temperature measuring instrument with cross-laser sighting, switchable optics for far-field and close focus measurement, contact temperature probe attachable, optical/audible alarm, reading memory, PC software incl. USB data transfer cable, aluminium case, battery and calibration protocol

Part no. 0563 8450

## testo 845 with integrated humidity module

testo 845, infrared temperature measuring instrument with cross laser sighting incl. humidity module, switchable optics for far-field and close focus measurement, contact temperature probe attachable, optical/audible alarm, reading memory, PC software incl. USB data transfer cable, aluminium case, battery and calibration protocol

Part no. 0563 8451

Description	Meas. range	Part no.
Fast-action surface probe with sprung thermocouple strip, also for uneven surfaces, measurement range short-term to +500°C, TC Type K	-60 to +300 °C	0602 0393
		
Robust air probe, T/C Type K	-60 to +400 °C	0602 1793
		

Accessories Ordering data	Part no.
Humidity module, upgradeable for testo 845 (0563 8450)	0636 9784
Plug-in mains adapter, 5 VDC 500 mA with European adapter, 100-250 VAC, 50-60 Hz	0554 0447
External fast charger for 1-4 AA rech. batteries, incl. 4 Ni-MH rech. batteries with individual cell charging and charge control display, incl. impulse trickle charging, integrated discharge function, with built-in international mains plug, 100-240 V, 300 mA, 50/60 Hz	0554 0610
Testo fast printer with wireless infrared interface, 1 roll thermal paper and 4 AA batteries, for printing out measurements on site	0554 0549
Spare thermal paper for printer (6 rolls), permanent ink, measurement data documentation legible for up to 10 years	0554 0568
testo saline pots for control and humidity adjustment of humidity probes, 11.3 %RH and 75.3 %RH with adapter for humidity probe	0554 0660
Adhesive tape, e.g. for bare surfaces (roll, L.: 10 m, W.: 25 mm), E = 0.95, temperature resistant to +250 °C	0554 0051
Silicone heat paste (14g), T <sub>max</sub> = +260°C, improves heat transfer in surface probes	0554 0004
ISO calibration certificate/temperature, infrared thermometer; calibration points +60°C; +120°C; +180°C	0520 0002
ISO calibration certificate/temperature, Infrared thermometers, calibration points -18°C, 0°C, +60°C	0520 0401

### Far-field measurement

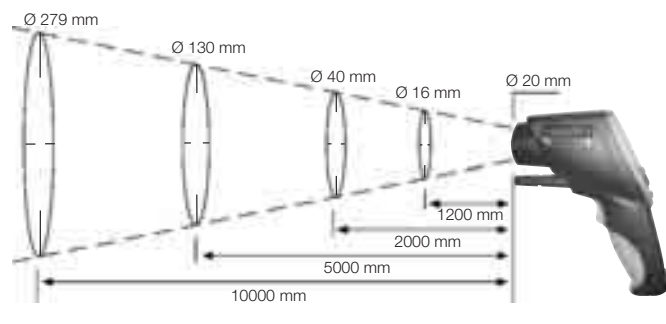

Probe socket for TC probes for determining emissivity

Aluminium case for instrument and accessories (included)

Checks surface temperature

Technical data			
Probe type	Infrared	Contact (type K)	Testo humid. sensor, cap.
Meas. range	-35 to +950 °C	-35 to +950 °C	0 to +100 %RH 0 to +50 °C -20 to +50 °C td
Accuracy	±2.5 °C (-35 to -20.1 °C) ±1.5 °C (-20 to +19.9 °C) ±0.75 °C (+20 to +99.9 °C) ±0.75% of mv (+100 to +950 °C)	±0.75 °C (-35 to +75 °C) ±1% of mv (+75.1 to +950 °C)	±2 %RH (2 to 98 %RH) ±0.5 °C (+10 to +40 °C) ±1 °C (remaining range)
Resolution	0.1 °C	0.1 °C	0.1 °C td
Emission factor	Adjustable 0.1 to 1.0		
Optical resolution	Far-field: (75:1) 16 mm, 1200 mm distance (90%) Close focus: 1 mm, 70 mm distance (90%)		
Measuring rate	t <sub>95</sub> : 250 ms; Scanning Max/Min/Alarm: 100 ms		
Dimensions	155 x 58 x 195 mm		
Battery type	2 AA batteries		
Battery life	25 h (without laser), 10 h (with laser without light), 5 h (with laser and 50% light)		
Material/Housing	ABS Black/gray, metal screen		
Oper. temp.	-20 to +50 °C		
Storage temp.	-40 to +70 °C		

### Close focus measurement

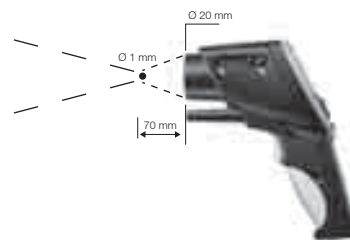

Switch to far-field measurement at a measurement distance > 250 mm



## Non-contact temperature measurement – With laser sighting

### testo 830-T1

The fast and versatile infrared thermometer with 1 point laser sighting

- 10:1 optics
- Adjustable emissivity 0.2 to 1.0
- Audible and visual alarm if limit is exceeded

#### testo 830-T1, 1 point laser sighting

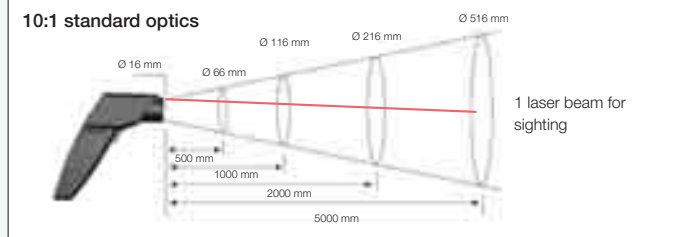

### testo 830-T2

The testo 830-T2 additionally has a 2 point laser sighting and connection option for an external probe for contact measurement.

- 12:1 optics
- °C contact measurement with attachable TC probe

#### testo 830-T2, 2 point laser sighting

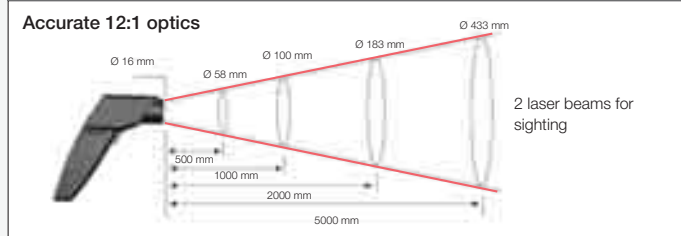

### testo 830-T3

The infrared thermometer with close focus optics and 2 point laser sighting is especially suited for temperature measurements on surfaces with a small diameter.

- Small measurement point of 2 mm, distance 25 mm
- °C contact measurement with attachable TC probe

#### testo 830-T3, close focus optics incl. 2 point laser sighting

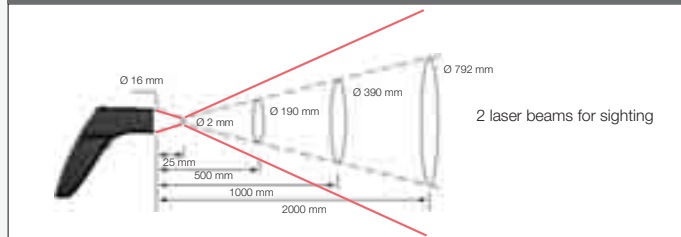

830-T2/-T3/-T4, 2-point laser measurement spot marking (real measurement point)

830-T2/-T3/-T4, possibility of connecting an external probe

For fast measurement of surface temperatures

Technical data	Infrared thermometer	Contact measurement (Type K)
Meas. range	-30 to +400 °C ( <b>830-T1/-T2/-T4</b> ) -25 to +400 °C ( <b>830-T3</b> )	-50 to +500 °C ( <b>830-T2/-T3/-T4</b> )
Accuracy ±1 digit at +23 °C ambient temperature	<b>830-T1/-T2:</b> ±1.5 °C or 1.5 % of mv (+0.1 to +400 °C) ±2 °C or ±2 % of mv (-30 to 0 °C) <b>830-T3:</b> ±1 °C (-20 to +100 °C) ±2 °C or ±2 % of mv (remaining range) <b>830-T4:</b> ±1.5 °C (-20 to 0 °C) ±2 °C (-30 to -20,1 °C) ±1 °C or 1 % of mv (remaining range)	±0.5 °C +0.5% of mv
Resolution	<b>830-T1/-T2-T3:</b> 0.5 °C <b>830-T4:</b> 0,1 °C	0.1 °C
Measurement rate	0.5 s	
Oper. temp.	-20 to +50 °C	Battery type 9V block battery
Storage temp.	-40 to +70 °C	Battery life 15 h
Weight	200 g	

### testo 830-T4

The temperature of small objects can be measured even at a small distance. At 1 m distance, the measurement spot diameter is only 36 mm.

- 30:1 optics
- 2-point laser for spot sighting
- °C contact measurement with connectable TC probe

#### testo 830-T4, 2-point laser measurement spot marking

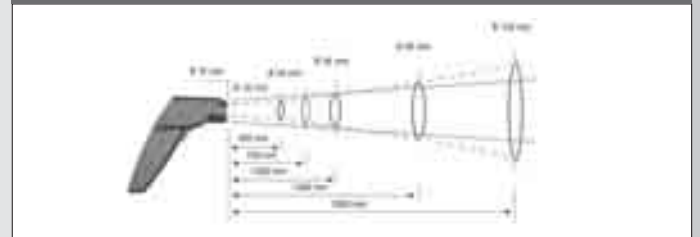

## Ordering data / Accessories testo 830-T1/-T2/-T3/-T4

### testo 830-T1

Infrared thermometer with 1 point laser sighting, adjustable limit values and alarm function, incl. batteries

Part no. 0560 8301

### testo 830-T2

Infrared thermometer with 2-point laser sighting, adjustable limit values, alarm function and connection of external probes, incl. batteries

Part no. 0560 8302

### testo 830-T3

IR temperature measuring instrument with close focus optics, incl. 2 point laser sighting, adjustable limit values and alarm function, contact temperature probe attachable, incl. battery

Part no. 0560 8303

### testo 830-T4

IR temperature measuring instrument with 30:1 optics and 2-point laser measurement spot sighting, incl. battery and factory calibration certificate with the meas. points +80 °C and +350 °C

Part no. 0560 8304

### Ordering data

### Part no.

#### Accessories for testo 830-T1/-T2/-T3/-T4

Adhesive tape, e.g. for bare surfaces (roll, L.: 10 m, W.: 25 mm), E = 0.95, temperature resistant to +250 °C	0554 0051
Leather case to protect measuring instrument, including belt holder	0516 8302
ISO calibration certificate/temperature; infrared thermometer; calibration points +60°C; +120°C; +180°C	0520 0002

#### Accessories for testo 830-T2/-T3/-T4 only

Waterproof immersion/penetration probe, TC Type K	0602 1293
Fast-action surface probe with sprung thermocouple strip, also for uneven surfaces, measurement range short-term to +500°C, TC Type K	0602 0393
Robust air probe, T/C Type K	0602 1793
ISO calibration certificate/temperature, for air/immersion probes, calibration point +60°C	0520 0063
ISO calibration certificate/temperature, for air/immersion probes, calibration points -18°C; 0°C; +60°C	0520 0001
ISO calibration certificate/temperature, meas. instr. with surface probe; calibration points +60°C; +120°C; +180°C	0520 0071

## Air temperature and infrared surface temperature in one instrument

### testo 810

testo 810 facilitates air temperature and simultaneously non-contact surface temperature measurement using one instrument. For instance, the surface temperature of a radiator can be easily compared to the air temperature in the room.

- Infrared measurement with 1-point laser spot marking and 6:1 optics
- Display of differential temperature, e.g. between window and air
- Hold function and min./max. values
- Emissivity adjustable
- Display illumination
- Protective cap for safe storage
- Incl. wrist strap and belt holder
- Incl. calibration protocol

### testo 810

testo 810; 2-channel temperature measuring instrument with infrared thermometer with laser spot marking and integrated NTC air thermometer, incl. protective cap, batteries and calibration protocol

Part no. 0560 0810



Safe storage and transport with protective cap, wrist strap and belt holder



Checking the surface temperature of a radiator with simultaneous measurement of ambient temperature

### Technical data

Probe type	Infrared	NTC
Meas. range	-30 to +300 °C	-10 to +50 °C
Accuracy ±1 digit	±2.0 °C (-30 to +100 °C) ±2% of mv (remaining range)	±0.5 °C
Resolution	0.1 °C	0.1 °C
Measurement rate	0.5 s	
Distance to measurement spot	6:1	
Meas. spot marking	1-point laser	
Spectral range	8 to 14 μm	
Oper. temp.	-10 to +50 °C	
Battery type	2 batteries Type AAA	
Battery life	50 h (average, without display illumination)	
Dimensions	119 x 46 x 25 mm (incl. protective cap)	
Weight	90 g (incl. battery and protective cap)	

### Accessories Ordering data

### Part no.

Adhesive tape, e.g. for bare surfaces (roll, L.: 10 m, W.: 25 mm), E = 0.95, temperature resistant to +250 °C	0554 0051
ISO calibration certificate/temperature, Infrared thermometers, calibration points -18°C, 0°C, +60°C	0520 0401
ISO calibration certificate/temperature, infrared thermometer; calibration points +60°C; +120°C; +180°C	0520 0002
ISO calibration certificate/temperature, for air/immersion probes, calibration points -8°C; 0°C; +40°C	0520 0181

## Material moisture, air moisture and temperature in one instrument

### testo 606

testo 606-1 measures material moisture. Using stored material characteristic curves for wood and building materials, material moisture is shown directly in percent by weight.

In addition to material moisture, testo 606-2 also measures air moisture and temperature. In this way, drying conditions, for example, can be reliably assessed on-site.

- Accurate wood moisture measurement with stored characteristic curves for beech, spruce, larch, oak, pine, maple

- Additional characteristic curves to locate wet points in building materials for cement screed, concrete, plaster, anhydrite screed, cement mortar, lime mortar, brick

- Hold function for easy readout of readings

#### Additional advantages of testo 606-2

- Measurement of temperature and humidity in ambient air
- Incl. dewpoint calculation and wet bulb



Safe storage and transport thanks to protective cap, wrist strap and belt case



Fast and easy wood moisture measurement

#### testo 606-1

testo 606-1; wood and material moisture meter, incl. protective cap, batteries and calibration protocol

Part no. 0560 6060

#### testo 606-2

testo 606-2; wood and material moisture meter with built-in moisture measurement and NTC air thermometer, incl. protective cap, batteries and calibration protocol

Part no. 0560 6062

#### Accessories Ordering data

Accessories Ordering data	Part no.
For testo 606-1: Spare electrodes (1 pair)	0192 5358
For testo 606-2: Spare electrodes (1 pair)	0192 5348

Technical data	606-1/-2	606-2	
Probe type	Material moisture based on conductivity	NTC	Testo humid. sensor, cap.
Meas. range	0 to 50 %	-10 to +50 °C	0 to 100 %RH
Accuracy ±1 digit	±1 % (Conductivity)	±0.5 °C	±2.5 %RH (5 to 95 %RH)
Resolution	0.1	0.1 °C	0.1 %RH
Oper. temp.	-10 to +50 °C		
Battery life	<b>testo 606-1:</b> 200 h (average, without display illumination) <b>testo 606-2:</b> 130 h (average, without display illumination)		
Dimensions	119 x 46 x 25 mm (incl. protective cap)		

## Measures differential pressure 0 to 100 hPa – Practical and robust

### testo 510

testo 510's differential pressure measurement is temperature-compensated for more accurate readings. The readings can be displayed in Pascal over the whole measurement range. Magnets on the back of the instrument allow you to work hands-free, for example, when tuning gas heaters. When used together with a Pitot tube, testo 510 measures air velocity. Air density can be compensated for accurate readings.

- Magnetic rear permits free-hand work
- Flow velocity measurement with Pitot tube (Pitot tube not included in delivery)
- Display in Pascal possible over entire measurement range

#### testo 510

testo 510; differential pressure meter incl. protective cap, batteries and calibration protocol

Part no. 0560 0510

#### Accessories Ordering data

Accessories Ordering data	Part no.
Hose set: Connection hose, silicone, 2 m long, max. load 700 hPa (mbar)	0554 0448
Pressure set with flue draught probe, includes 2 x silicone hoses each with Ø 4mm and Ø6mm, 4mm and 6mm T-piece, connecting piece	0554 3150
Pitot tube, 350 mm long, stainless steel, for measuring flow velocity	0635 2145
Pitot tube, 500 mm long, stainless steel, for measuring flow velocity	0635 2045
ISO calibration certificate/Pressure, Differential pressure; 3 points distributed over meas. range	0520 0095
ISO calibration certificate/pressure, differential pressure; 5 points distributed over meas. range	0520 0005



Safe storage and transport thanks to protective cap, wrist strap and belt case

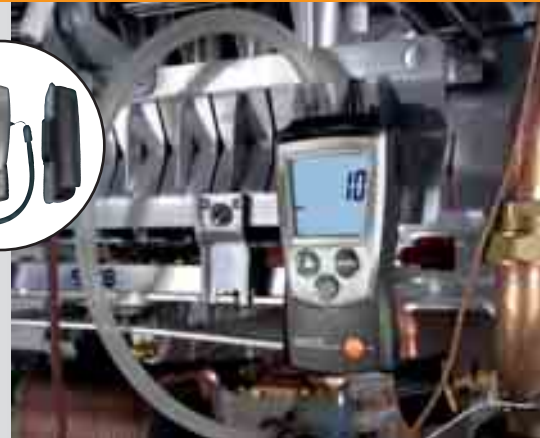

Differential pressure measurement on a gas heater

Technical data	Differential pressure probe
Probe type	Differential pressure probe
Meas. range	0 to 100 hPa
Accuracy ±1 digit	±0.03 hPa (0 to 0.30 hPa) ±0.05 hPa (0.31 to 1.00 hPa) ±(0.1 hPa + 1.5 % of mv) (1.01 to 100 hPa)
Resolution	0.01 hPa
Selectable units	hPa, mbar, Pa, mmH <sub>2</sub> O, inH <sub>2</sub> O, inHg, mmHg, psi, m/s, fpm
Oper. temp.	0 to +50 °C
Battery type	2 batteries Type AAA
Battery life	50 h (average, without display illumination)
Dimensions	119 x 46 x 25 mm (incl. protective cap)

## Notes

## Pressure measurement for gas and water installation

### testo 312-2/-3

The testo 312-2 and 3 manometers are DVGW approved and correspond to TRGI for all pressure adjustments and pressure inspections on gas heating boilers. Use the testo 312-2 precision manometer to check flue gas draught, differential pressure in the combustion chamber compared with ambient pressure or gas flow pressure with high resolution. Fine pressures with a resolution of 0.01 hPa can be measured in the range from 0 to 40 hPa. The versatile testo 312-3 pressure meter supports load and gas-tightness tests on gas and water pipelines up to 6000 hPa (6 bar).

- Switchable measuring ranges, ideal resolution
- Compensation of temperature controlled reading deviations
- Alarm display when user defined limit values are exceeded
- Clear display with time

#### testo 312-2

##### Up to 40/200 hPa

Precision manometer up to 40/200 hPa, DVGW approval, incl. alarm display, battery and calibration protocol

Part no. 0632 0313

#### testo 312-3

##### Up to 300/6000 hPa

Versatile pressure meter up to 300/6000 hPa, DVGW approval, incl. alarm display, battery and calibration protocol

Part no. 0632 0314

#### Suitable probes at a glance

#### Part no.

Pressure set with flue draught probe, consisting of: 2 x silicone hoses Ø 4 mm and Ø 6 mm respectively, 4 mm and 6 mm T-piece, connection piece

0554 3150

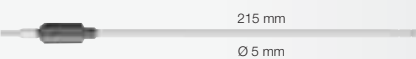

Technical data	testo 312-2	
Meas. range	-40 to +40 hPa	-200 to +200 hPa
Accuracy ±1 digit	±1.5% of mv. (+3 to +40 hPa) ±0.03 hPa (0 to +3 hPa)	±0.5 hPa (0 to +50 hPa) ±2 hPa (+50 to +200 hPa)
Resolution	0.01 hPa	0.1 hPa
Overload	±1000 hPa	±1000 hPa
Technical data	testo 312-3	
Meas. range	-300 to +300 hPa	-6000 to +6000 hPa
Accuracy ±1 digit	±0.5 hPa (0 to +50 hPa) ±1.5 hPa (+50 to +300 hPa)	±2% of mv. (+400 to +2000 hPa) ±4% of mv. (+2000 to +6000 hPa) ±4 hPa (0 to +400 hPa)
Resolution	0.1 hPa	1 hPa
Overload	±8000 hPa	±8000 hPa
Common data	testo 312-2/-3	
Dimensions	215 x 68 x 47 mm	
Weight	300 g	

Printout

With alarm function

Differential pressure measurement on heating units

Printers and Accessories	Part no.
Testo fast printer with wireless infrared interface, 1 roll thermal paper and 4 AA batteries	0554 0549
External fast charger for 1-4 AA rech. batteries, incl. 4 Ni-MH rech. batteries with individual cell charging and charge control display, incl. impulse trickle charging, integrated discharge function, with built-in international mains plug, 100-240 V, 300 mA, 50/60 Hz	0554 0610
Spare thermal paper for printer (6 rolls)	0554 0569
Spare thermal paper for printer (6 rolls), permanent ink, measurement data documentation legible for up to 10 years	0554 0568
Additional Accessories and Spare Parts	Part no.
9V rech. battery for instrument, instead of battery	0515 0025
Recharger for 9V rechargeable battery, for external recharging of 0515 0025 battery	0554 0025
Transport and Protection	Part no.
TopSafe (protection case), with bench stand, protects instrument from dirt and impact	0516 0443
Case, for secure storage of measuring instrument	0516 0191
Transport case (plastic), for transport and secure storage of measuring instrument and accessories	0516 3120

## Complete test system for gas/water installation

### Testing system set

Everything you need to inspect gas and water pipeline installations: Check pressure drop using the testo 312-3 electronic pressure meter. Measurement results are documented on the fast printer. Using the slide rule, you can quickly determine the amount of gas leaking and thus the serviceability of the gas pipelines. A gas leak is quickly detected by testo 316-1.

- Load and gas-tightness tests on gas pipelines
- Pressure check on water pipelines
- Fast detection of amount of leaking gas
- Efficient leak detection



Display with reading



Printout with date



Pressure test on water pipes (3-5 bar test pressure)

Accessories	Ordering data	Part no.
Pressure drop test set 200 mbar, incl. manual bulb pump, hoses, T-fitting w/ valve, conical test stopper 1/2"		0554 3153
Test pump to produce test pressure		0554 3157
Single-pipe counter cap, connects test fittings to pipe. Simply dismantle gas counter, attach single-pipe counter cap and connect hose		0554 3156
Two-valve branch (brass) to connect 2 or more pipes, can be blocked off separately		0554 3161
Single-valve stop to block off pipe, e.g. when changing hoses during a test		0554 3162
LW 6 connection hose, To connect T-fitting/single-pipe counter cap or for extension purposes		0554 3158
Conical test stop 1/2" for connecting test set to the gas pipe 19-32 mm, Connects test fittings to pipe		0554 3151
Conical test stop 3/4" for connecting the test set to the gas pipe 24-44 mm, Connects test fittings to pipe		0554 3155
Conical test stop 1" to connect test fittings to gas pipe 35-65 mm, Connects test fittings to pipe		0554 3152
High pressure stage stop 3/8" and 3/4", To connect test fittings to gas pipe		0554 3163
High pressure stage stop 1/2" and 1", To connect test set to gas pipe		0554 3164
Leak detection spray for spraying on the gas pipe, shows leaking points where bubbles form, To detect leaks (bubbles appear) in gas pipes		0554 3166
System case for the complete test system, Ensures orderly storage of case contents		0554 3165
Slide rule to quickly determine serviceability		0554 3169
DKD calibration certificate/pressure, diff. and pos. pressure; 6 meas. points distributed over meas. range (>0.6% of fsv)		0520 0225

### Testing system set

testo 312-3 pressure meter

TopSafe for testo 312

Fast printer

testo 316-1 gas leak detector

TopSafe for testo 316-1

Accessories: Pressure drop test set 200 mbar, testing pump, single-pipe counter cap, two valve T-fitting, single valve barrier, connection hose

LW 6, conical test plugs 1/2", 3/4", high pressure stage stops 3/8", 3/4", 1/2", 1", leak detection spray, slide rule, system case

**Part no. 0563 0314**

### High pressure set with case (without instrument)

Pressure drop test set, 200 mbar

Testing pump, greater than 500 mbar

Single-pipe counter cap

Two-valve T-fitting

Single-valve barrier

Connection hose LW

Conical test plugs 1/2" and 3/4"

High pressure stage stop 3/8", 1/2", 3/4", and 1"

Leak detection spray

System case

Please order the testo 312-3 or testo 312-2 instrument suitable for your requirements (see opposite page)

**Part no. 0554 3160**

## Fulfilling all measurement tasks on gas heating systems and on gas and water pipes.

### Would you like to carry out all necessary tests with one instrument?

With the electronic differential pressure gauge testo 312-4, fine pressure measurements can be carried out quickly and reliably when checking the resting pressure and flow pressure of gas, and when setting the correct jet pressure on gas burners and boilers.

Tests on newly installed gas pipes (load and gas-tightness tests), or on pipes already in use (serviceability tests) can also be carried out quickly and in accordance with the law. The user-friendly menu structure for the respective measurements considerably eases work.

Time and money can be saved in customer service, especially when checking the gas pressure regulator, thanks to the automatic measurement value recording over several hours by testo 312-4 (max. 25,000 measurement values). The use of special C-Flex hoses guarantees the gas-tightness of the hoses, particularly in long-term measurements. The simultaneous recording of pressure and temperature allows the detection of unusual pressure fluctuations which are graphically analyzed by the Easyheat PC software, and can thus be easily explained to the customer.

Load tests and leakproofness tests on drinking water and waste water pipes can be carried out without complications using the handy high-pressure probe. The external probe provides excellent protection for the instrument from water and high pressures.



Load, gas-tightness and serviceability test by pressure drop on gas pipes as a load test for newly installed pipes



Testing the pressure regulator in the course of recording the measurement values over a defined period.



Checking the gas connection pressure and gas flow pressure as well as adjusting the jet pressure.



Pressure tests on waste water and drinking water pipes.



## Fulfilling all measurement tasks on gas heating systems and on gas and water pipes.

### testo 312-4

A measuring instrument for carrying out all necessary tests on gas heaters and pipes as well as water pipes. Inherently safe thanks to the use of C-Flex hoses with high impermeability. Legally compliant measurement procedure for pre-test, main test and leakage quantity measurement on gas pipes. Recording of measurement values over a defined period (e.g. 24 h) and data transfer and analysis on PC software incl. graphic presentation.

- Gas-tightness and serviceability test by pressure drop on gas pipes according to DVGW-TRGI 2008
- Load test on gas pipes according to DVGW-TRGI 2008 with the help of the high pressure probe
- Checking the regulator by recording the measurement values over a defined period
- Checking the gas connection pressure and gas flow pressure as well as setting the jet pressure on gas burners and boilers
- Pressure tests on drinking water pipes with water using the high-pressure probe according to DIN 1988 (TRWI) as well as with air according to the ZVSHK information sheet
- Pressure test on waste water pipes according to DIN EN 1610 using the high pressure probe

#### testo 312-4

Differential pressure gauge testo 312-4

Part no. 0632 0327

Accessories Ordering data	Part no.
Pressure set for gas pressure measurement on heating systems	0554 0449
Hose set for testo 312-4	0554 3172
Balloon pump with release valve	0554 3173
Conical test stop 1/2" (19 - 32mm)	0554 3151
Conical test stop 3/4" (24 - 44 mm)	0554 3155
testo 316-1, gas leak detector	0632 0316
Single-pipe counter cap	0554 3156
Two-valve branch (brass) to connect 2 or more pipes, can be blocked off separately	0554 3161
Single-valve stop to block off pipe	0554 3162
LW 6 connection hose	0554 3158
Leak detection spray for spraying on the gas pipe, shows leaking points where bubbles form	0554 3166
Desk-top power supply with international connection options	0554 1143
Test pump to produce test pressure	0554 3157
9V rech. battery for instrument	0515 0025
Recharger for 9V rechargeable battery	0554 0025
Testo fast printer with wireless infrared interface, 1 roll thermal paper and 4 AA batteries	0554 0549
Spare thermal paper for printer (6 rolls), permanent ink	0554 0568
TopSafe (protection case)	0516 0446
TopSafe for testo 316, protection case incl. stand, protects from dirt and impact	0516 0189
System case	0516 3121
High-pressure probe up to 25 bar	0638 1743
High pressure stage stop 3/8" and 3/4"	0554 3163
High pressure stage stop 1/2" and 1"	0554 3164
Pipe wrap probe for pipes with diameter of up to 2", for flow/return temp. meas. in hydronic systems	0600 4593
Quick-action surface probe with sprung thermocouple strip, measuring range short-term to +500°C	0604 0194
Connection cable, length 1.5 m, for probes with plug-in heads	0430 0143
easyheat PC analysis software, shows measurement in form of diagrams, tables and manages customer data.	0554 3332
RS232 cable	0409 0178

#### Basic set testo 312-4

Differential pressure gauge testo 312-4
Hose set for testo 312-4
Balloon pump with release screw
Conical test plug 1/2"
Conical test plug 3/4"
Testo fast printer
Pressure set for gas pressure measurements on heating systems
System case

Part no. 0563 1327

#### High-pressure set testo 312-4

Differential pressure gauge testo 312-4
Hose set for testo 312-4
Balloon pump with release screw
Conical test plug 1/2"
Conical test plug 3/4"
Testo fast printer
Pressure set for gas pressure measurements on heating systems
High-pressure plug 3/8" and 3/4"
High-pressure plug 1/2" and 1"
High-pressure probe 1up to 25 bar
System case

Part no. 0563 1328

#### Technical data

<b>Pressure (internal sensor in the testo 312-4)</b>	
Meas. range	0 to 200 hPa
Accuracy	±0.03 hPa (0 to +3 hPa) ±1.5% of mv (+3.1 to +40 hPa) ±2 hPa or ±1% of fsv (+41 to +200 hPa)
<b>Temperature (via external temperature probe Type K)</b>	
Meas. range	dependent on probe type used
Accuracy	±0.4 °C (-100 to +200 °C) ±1 °C (remaining range)
<b>Pressure (via high-pressure probe)</b>	
Meas. range	0 to 25 bar
Accuracy	±0.5% of fsv
Resolution	10 hPa
<b>Miscellaneous instrument data</b>	
Interface for printer	infrared
Interface for PC	RS 232
PC software	Easyheat
Measurement data store	Approx. 25.000 readings
Measurement rate	auto 1 s to 24 h fast 0.04 s
Dimensions	219 x 68 x 50 mm
Weight	Approx. 600 g
Warranty	2 years

## Serviceability in gas and water pipes – fast and easy

### 1 Unique

Efficient measurement due to **absolute pressure compensation** testo 314 independently compensates fluctuations in absolute pressure during volume flow measurement via absolute pressure compensation.

### 2 Fast

**Zeroing phase for connected pipe**

To determine  $\Delta P$  efficiently and quickly, zeroing to ambient air pressure takes place while the measurement is in progress. This eliminates interruptions and removal of pipes.

### 3 Efficient

**Measuring using standard test pressure compensation with feeding unit**

The flow test which is independent of gas mains, has the advantage that pressure fluctuations in pipes can be compensated. The built-in flow pressure controller (gas bubble with gas feeding unit) compensates for fluctuations. The finely adjusted value is displayed in testo 314 along with the leakage amount.

- Load and gas-tightness test on gas pipes
- Fast measurement of amount of gas leaking according to DVGW-TRGI 2008 VP 952
- Efficient detection of gas leaks using testo 316-1
- Analysis software to show course of measurement
- Serviceability test on gas pipes
- Data recording for testing pressure regulator
- Analysis with PC software
- Pressure test on waste water pipes according to DIN EN 1610 using the high pressure probe (available as an option)

#### testo 314

Pressure meter with built-printer, from -1000 mbar to +1000 mbar

Part no. 0560 3140



#### Technical data

Pressure meas. range	0 to 1000 mbar
Resolution	0.1 mbar
Accuracy	$\pm 0.5$ mbar; $\pm 3\%$ of mv
Volume flow meas. range	0 to 8 l/h
Resolution	0.1 l/h
Accuracy	$\pm 0.1$ l/h; $\pm 5\%$ of mv
Battery life	> 5 h
Dimensions	252 x 115 x 58 mm
Weight	Approx. 728 g

See Page 44 for Technical Data on testo 316



Built-in printer with large, backlit graphics display



Standard test pressure compensation with feeding unit



The complete testing system in a case

### The complete testing system set for gas/water pipes

- testo 314, pressure meter with built-in printer, from -1000 mbar to +1000 mbar
- Mains unit 230 V/8 V/1 A for separate use of control unit
- System case incl. hose set for connection to the gas pipe
- testo 316-1, electronic gas leak detector with flexible measurement probe
- TopSafe for testo 316, indestructible protection case incl. stand, protects from dirt and impact
- Leak detection spray for spraying on gas pipe, bubbles indicate leaking points
- Conical test stop 1/2" for connecting test set to the gas pipe 19–32 mm
- Conical test stop 3/4" for connecting test set to the gas pipe 24–44 mm
- High pressure step plug 3/8" and 3/4" for connecting test set to the gas pipe
- High pressure step plug 1/2" and 1" for connecting test set to the gas pipe
- Pressure release plug
- Single-valve block for blocking off the pipe
- Double valve branch (brass) for connecting 2 or more pipes, can be blocked off separately
- Test pump for generating test pressure

Part no. 0563 3140 70

Accessories Ordering data	Part no.
Gas feeding unit for testo 314, for battery-operated measurement	0554 3142
Mains unit 230 V/ 8 V/ 1 A, for instrument (European plug), for mains operation and battery recharging	0554 1084
testo 316-1, Electronic gas leak detector with flexible measurement probe and battery	0632 0316
Hose set for connection to gas pipe with test pump and conical test plug 1/2"	0554 3141
Single-pipe counter cap, connects test fittings to pipe	0554 3156
Two-valve branch (brass) to connect 2 or more pipes, can be blocked off separately	0554 3161
Single-valve stop to block off pipe	0554 3162
LW 6 connection hose, To connect T-fitting/single-pipe counter cap or for extension purposes	0554 3158
Conical test stop 1/2" for connecting test set to the gas pipe 19-32 mm	0554 3151
Conical test stop 3/4" for connecting the test set to the gas pipe 24-44 mm	0554 3155
Conical test stop 1" to connect test fittings to gas pipe 35-65 mm	0554 3152
High pressure stage stop 3/8" and 3/4", To connect test fittings to gas pipe	0554 3163
High pressure stage stop 1/2" and 1", To connect test set to gas pipe	0554 3164
Leak detection spray for spraying on the gas pipe, shows leaking points where bubbles form	0554 3166
Spare thermal paper for printer (6 rolls)	0554 0569
Pressure set for gas pressure measurement on heating systems	0554 0449
Test pump to produce test pressure	0554 3157
Pressure release plug	0554 3171
ISO calibration certificate/flow in gases, 5 measurement points	0520 0084

Transport and Protection	Part no.
TopSafe for testo 316, protection case incl. stand, protects from dirt and impact	0516 0189
System case with hose set, test pump and conical test plug 1/2"	0516 3140
Software and Accessories	Part no.
easyheat PC analysis software, shows measurement in form of diagrams, tables and manages customer data.	0554 3332
RS232 cable, connects instrument to PC (1.8 m) for data transfer	0409 0178
Probes and Accessories	Part no.
High-pressure probe up to 25 bar	0638 1743
Pipe wrap probe for pipes with diameter of up to 2", for flow/return temp. meas. in hydronic systems	0600 4593
Quick-action surface probe with sprung thermocouple strip, measuring range short-term to +500°C	0604 0194
Connection cable, PUR coating material	0430 0143

## Gas leak detector

### testo 317-2

Highly practical gas leak detector for fast checks on gas pipe connections, with visual bar display.

- Self-test by sensor following switch-on
- Audible confirmation of readiness to operate
- Rising alarm sounds with increasing gas concentrations

- Non-stop sound if alarm threshold is exceeded
- Battery monitoring with visual display

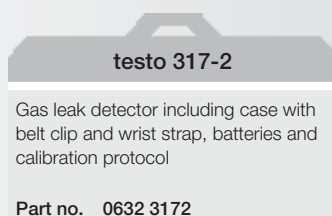

Technical data		
Meas. range	0 to 20.000 ppm CH <sub>4</sub>	0 to 10.000 C <sub>3</sub> H <sub>8</sub>
Display	8 segment trend display	
Alarm thresholds	10.000 ppm CH <sub>4</sub>	5000 C <sub>3</sub> H <sub>8</sub>
Lower response thresholds	100 ppm CH <sub>4</sub> 50 C <sub>3</sub> H <sub>8</sub>	
t90	< 5 s	Heat-up time 60 s
Battery type	2 batteries type micro AAA 1.5 V (LR03)	
Battery life	4 h (LR03)	
Oper. temp.	-5 to +45 °C	Storage temp. -20 to +50 °C
Audible emitter	85 dB(A)	



Shows gas concentration in visual bar display



Audible warning about dangerous gas concentrations e.g. at gas pipe connections

## Detector for leaks in natural gas pipes

### testo 316-1

The testo 316-1 gas leak detector quickly detects even the smallest leaks.

- Bendable measurement probe for inaccessible pipes
- Optical and audible alarm if limit value is exceeded
- TopSafe case protects from dirt and impact (optional)

TopSafe case protects from dirt and impact (optional)

#### testo 316-1

Electronic gas leak detector with flexible measurement probe and battery

Part no. 0632 0316

#### Technical data

Meas. range	0 to 10,000 ppm CH <sub>4</sub>
1st alarm limit	from 200 ppm CH <sub>4</sub>
2nd alarm limit	10.000 ppm CH <sub>4</sub>
Battery life	> 5 h
Dimensions	190 x 57 x 42 mm

#### Accessories Ordering data

#### Part no.

TopSafe for testo 316, protection case incl. stand, protects from dirt and impact	0516 0189
Transport case (plastic), for transport and secure storage of measuring instrument and accessories	0516 3120



Checks for leaks in domestic gas pipes

## The gas leak detector for a fast overview

### testo 316-2

The testo 316-2 is extremely user-friendly and ideally suited to fast check measurements thanks to its integrated pump, its optical presentation of the gas concentrations detected, and the integrated rechargeable battery.

- Optical and audible alarm with bar display for increasing and dangerous gas concentrations
- Trend display shows maximum leakage
- Integrated pump
- Flexible measurement probe for inaccessible places
- Earphone connection for secure leakage localization in loud surroundings
- High duration of use thanks to rechargeable battery

#### testo 316-2

Electronic gas leak detector with flexible measurement probe, incl. case, mains charger and earphones

Part no. 0632 3162

#### Technical data

Meas. range	10 ppm to 4,0 Vol. % CH <sub>4</sub> 10 ppm to 1,9 Vol. % C <sub>3</sub> H <sub>8</sub> 10 ppm to 4,0 Vol. % H <sub>2</sub>
1st alarm limit	200 ppm CH <sub>4</sub> 100 ppm C <sub>3</sub> H <sub>8</sub> 200 ppm H <sub>2</sub>
2nd alarm limit	10.000 ppm CH <sub>4</sub> 5.000 ppm C <sub>3</sub> H <sub>8</sub> 10.000 ppm H <sub>2</sub>
Battery life	6 h
Dimensions	190 x 57 x 42 mm

#### Accessories Ordering data

#### Part no.

Earphones, black with ear cushions	0554 5001
Mains unit (output: 12V, DC, 300mA)	0554 1093



## Gas detector – Detects even the smallest gas leaks

### testo gas detector

According to DVGW leaflet G 465-4, gas detectors are approved for above-ground gas detection up to the "lower explosive limit (LEL)". Testo's gas detector is a multi-range gas detector for the gas types methane, propane and hydrogen. Gas concentrations are measured by the semi-conductor sensor in the ppm range and are shown in the display with a resolution of 1 ppm.

- Audible signals when approaching the lower explosion limit
- Continuous sound and display when the explosion limit is reached

Flexible probe extension for difficult-to-access points



Gas detection and leak location in gas pipelines and installations

#### Technical data

Display range	Methane CH <sub>4</sub>	1 to 999 ppm, 0.1 to 4.4 Vol.%
	Propane C <sub>3</sub> H <sub>8</sub>	1 to 999 ppm, 0.1 to 1.9 Vol.%
	Hydrogen H <sub>2</sub>	1 to 999 ppm, 0.1 to 4.0 Vol.%
Resolution	1 ppm / 0.1 Vol.%	
First reaction	>10 ppm	
Power supply	Built-in rechargeable block, NiMH, 1600 mAh	
Ex-Protection	Sensor intrinsically safe to DMT test institute	
Reaction time t90	2-3 s	Oper. temp. -15 to +40 °C
Storage temp.	-25 to +70 °C	Dimensions 190 x 40 x 28 mm
Rech. battery life	>8 h	Weight 320 g
Warranty	2 years on instr., 1 year on sensor	

#### testo gas detector

Gas detector incl. flexible probe extension, rechargeable battery and mains unit for mains operation and battery recharging, with calibration protocol

**Part no. 0632 0323**

## Flue gas spillage detector

### testo 317-1

The testo 317-1 spillage detector efficiently locates escaping heating flue gases. The practical instrument immediately gives off an optical and acoustic alarm making a visual inspection unnecessary. The bendable probe makes it ideal for use at hard-to-access points.

- Reliable detection of leaking flue gases
- Bendable measurement probe for inaccessible points
- Audible and visual alarm

#### testo 317-1

Spillage detector with flexible probe, incl. battery

Part no. 0632 3170

#### Technical data

Reaction time	2 s
Length of probe pipe	200 mm
Diameter/Probe pipe tip	Ø 10 mm
Dimensions	128 x 46 x 18 mm
Weight	300 g



Establishes if flue gases have been drawn off completely from the burner

## Ambient carbon monoxide warning

### testo 317-3

The testo 317-3 CO monitor detects the presence of carbon monoxide in the surrounding area and warns the user both visually and audibly about dangerous gas concentrations e.g. when installing and servicing gas heaters.

- 3 year warranty on CO sensor
- No initialisation phase, instrument is ready to operate immediately
- Adjustable alarm threshold
- CO zeroing at site

#### testo 317-3

testo 317-3 CO monitor incl. carrying case with belt clip, headphones, wrist strap, sampler and calibration protocol

Part no. 0632 3173

#### Technical data

Meas. range	0 to +1999 ppm
Resolution	1 ppm
Accuracy	±10 ppm (0 to +99 ppm) ±10 % (+100 to +499 ppm) ±20 % (>+500 ppm)
Reaction time (t90)	40 s
Battery life	150 h (with beeper switched off)
Oper. temp.	-5 to +45°C
Warranty	2 years on the instrument 3 years on the CO sensor



Visual and audible alarm



Warns about dangerous gas concentrations e.g. during installation and maintenance work

## CO warning measurement – For your safety

### testo 315-2

Use testo 315-2 to check the CO level in ambient air. Even low concentrations of the highly poisonous gas are detected. In this way, you can judge whether the burner flue gases are being fully drawn off.

- Reliable CO warning
- Adjustable alarm limits
- Audible and visual alarm
- Automatic zero point adjustment
- Data printout on site with fast printer (optional)
- TopSafe case protects from dirt, water and impact (optional)

#### testo 315-2

CO warning instrument, with battery and calibration protocol

Part no. 0632 0317



Fast printer with printout



CO zeroing in contaminated room



Safe CO level check

#### Printer and Accessories

Testo fast printer with wireless infrared interface, 1 roll thermal paper and 4 AA batteries

Part no. 0554 0549

External fast charger for 1-4 AA rech. batteries, incl. 4 Ni-MH rech. batteries with individual cell charging and charge control display, incl. impulse trickle charging, integrated discharge function, with built-in international mains plug, 100-240 V, 300 mA, 50/60 Hz

Part no. 0554 0610

Spare thermal paper for printer (6 rolls)

Part no. 0554 0569

Spare thermal paper for printer (6 rolls), permanent ink

Part no. 0554 0568

#### Additional Accessories and Spare Parts

9V rech. battery for instrument, instead of battery

Part no. 0515 0025

Recharger for 9V rechargeable battery, for external recharging of 0515 0025 battery

Part no. 0554 0025

Spare particle filter (10 off), for CO flue gas probe

Part no. 0554 0040

#### Transport and Protection

TopSafe (protection case), with bench stand, protects instrument from dirt and impact

Part no. 0516 0443

Multi-function clip (for instrument with TopSafe) consisting of multi-function clip and magnetic holder

Part no. 0554 0398

Case, for secure storage of measuring instrument

Part no. 0516 0191

Transport case (plastic), for transport and secure storage of measuring instrument and accessories

Part no. 0516 3120

#### Calibration Certificates

ISO calibration certificate/flue gas, calibration points 2.5% O<sub>2</sub>; 100 and 1000 ppm CO; 800 ppm NO; 80 ppm NO<sub>2</sub>; 1000 ppm SO<sub>2</sub>

Part no. 0520 0003

ISO calibration certificate/CO, CO probes; calibration points 0; 80 ppm

Part no. 0520 0039

#### Technical data

Meas. range	0 to +2000 ppm CO
Accuracy	±10 ppm CO (0 to +100 ppm CO) ±10% of mv (+100 to +2000 ppm CO)
Resolution	1 ppm CO
Alarm limits	50/100/500 ppm
Zero point adjustment	Automatically when switched on
Dimensions	215 x 68 x 47 mm
Weight	400 g



## Versatile CO measurement – For safety and service

### testo 315-1

The testo 315-1 provides you with all the measurement functions needed to service gas heating systems. While measuring draught, pressure difference or temperature, the instrument can also simultaneously show the CO level in the ambient air. In this way, you always have the system's safety under your watchful eye.

- Efficient CO warning
- Three alarm limits are user-defined
- Audible and visual alarm
- Automatic zero point adjustment
- Two temperature inputs to compare the flow and return temperature
- Compensation of temperature-related reading deviations
- TopSafe case protects from dirt, water and impact (optional)

#### testo 315-1

CO warning and servicing instrument for gas heating systems with battery and calibration protocol

Part no. 0632 0315



Parallel CO alarm



Checks gas flow pressure

Accessories Ordering data	Part no.
9V rech. battery for instrument, instead of battery	0515 0025
Recharger for 9V rechargeable battery, for external recharging of 0515 0025 battery	0554 0025
TopSafe (protection case), with bench stand, protects instrument from dirt and impact	0516 0443
Testo fast printer with wireless infrared interface, 1 roll thermal paper and 4 AA batteries	0554 0549
Transport case (plastic), for transport and secure storage of measuring instrument and accessories	0516 3120

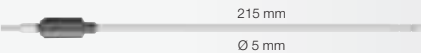
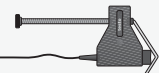
Suitable probes at a glance	Part no.
Pressure set with flue draught probe, consisting of: 2 x silicone hoses Ø 4 mm and Ø 6 mm respectively, 4 mm and 6 mm T-piece, connection piece 	0554 3150
Pipe wrap probe for pipe diameter 5 to 65 mm, with exchangeable measuring head. Meas. range short-term to +280°C, TC Type K 	0602 4592

Technical data				
Meas. range	0 to +2000 ppm CO	-200 to +200 hPa	-40 to +40 hPa	-40 to +600 °C
Accuracy ±1 digit	±10% of mv (+100 to +2000 ppm CO) ±10 ppm CO (0 to +100 ppm CO)	±0.5 hPa (-49.9 to +49.9 hPa) ±1.5 hPa (-200 to -50 hPa) ±1.5 hPa (+50 to +200 hPa)	±1.5% of mv (-40 to -3 hPa) ±1.5% of mv (+3 to +40 hPa) ±0.03 hPa (-2.99 to +2.99 hPa)	±0.5% of mv (+100 to +600 °C) ±0.5 °C (0 to +99 °C)
Resolution	1 ppm CO (0 to +2000 ppm CO)	0.1 hPa (-200 to +200 hPa)	0.01 hPa (-40 to +40 hPa)	0.1 °C (-40 to +600 °C)
Display	LCD, 2 lines		Battery type	9V block battery
Material/Housing	ABS		Battery life	16 h
Oper. temp.	+5 to +45 °C		Dimensions	215 x 68 x 47 mm
Storage temp.	-20 to +50 °C		Weight	400 g

## Flexible fiberscope for fast diagnoses

### testo 319

The testo 319 fibre-glass fiberscope facilitates easy inspections at difficult-to-access points such as in air ducts, ventilators, machines and motors etc. Diagnoses such as corrosion, friction wear, condition of welding joints, loose parts and lots more can be made very early, very quickly and very easily using endoscopy.

The flexible testo 319 can be guided through hollow spaces, bore holes and bends. You can adjust the focus using the focussing wheel. In this way the damaged point can be appraised without the need for dismantling.

Highly flexible with a bending radius of only 50 mm, with middle flexibility or stiff; extraordinarily versatile applications thanks to different, push-on casings.

- Optics: 6,000 pixels with a field of view of 50°
- Low bending radius (50 mm), small diameter (6 mm)
- Stability thanks to Decabon pipe
- Gooseneck casing for medium flexibility
- 3-arm gripper: Grips small objects (optional)



LED light, high contrast display

Inspects air duct, with gooseneck casing, middle flexibility



Checks insulations by using the stability of the Decabon tube

#### testo 319

testo 319 fiberscope

**Part no. 0632 3191**

#### testo 319 set

Fiberscope set, consisting of testo 319 fiberscope, gooseneck tube, magnet and mirror attachments, bag

**Part no. 0563 3191**

Accessories Ordering data	Part no.
Flexible push-on gooseneck tube,	0554 3196
Decabon push-on tube	0554 3191
Two-channel push-on hose	0554 3190
Magnet attachment	0554 3195
Mirror attachment 45° angle	0554 3194
Temperature probe for two-channel hose	0554 3193
3-arm gripper, for two-channel hose	0554 3192
Bag for basic set testo 319, gooseneck tube, magnet and mirror attachment	0516 3192

#### Technical data

No. of pixels:	6,000
Fibre-optic field of view:	50°
Angle of field of view:	45° +/- 5°
Min. focus distance:	15 mm (close)
Max. focus distance:	150 mm (light)
Operating and storage temperature:	-20° to + 60°C
Working temperature/Probe:	-20° to + 80°C
Probe diameter:	6.5 mm
Probe length:	1247 mm +/- 6
Max. bending radius:	50 mm
Light source:	LED 2 point light
Probe resistance:	Probe tip water-proof up to handle
	Short-term resistance to silicone oils, petrol and kerosene. Oils or petrol must be wiped off immediately after immersion
Housing:	Black
Battery type:	3 AA Mignon 1.5 V

## Robust measuring instruments for commissioning, service and maintenance on heat pumps

### testo 560 and testo 556

The refrigeration system analyzers are the professional solution for the commissioning, maintenance and service of heat pumps and air conditioning systems.

Two temperature-compensated pressure sensors as well as externally connectable temperature probes are available for the automatic calculation of superheating or subcooling.

Practical pipe wrap probes allow the measurement of the flow and return temperatures of the heating loop. For measurements on an air or water heat pumps, additional air temperature probes are available. The temperatures of the refrigerant loop can also be measured.

Some manufacturers also require that the temperature of the compressor housing is checked. This too, can be recorded without difficulty.

Equipped with a high-quality sensor for the measurement of vacuum, the testo 560 is also suitable for the evacuation of heat pumps. This allows it to be also used for commissioning. All measurement values can be securely stored in the internal memory (60,000 measurement values), and archived and analyzed as needed using the EasyKool software.



Large backlit display and easy operation via menu buttons



Robust design: shock-absorbent protective cover and stowable valve knobs



New carabiner hook design with integrated instrument security (lock optional)



System and error analysis with PC software "EasyKool"



## The professional solution for commissioning, service and maintenance

### testo 556

The all-round talent for the complete recording of all flow and return temperatures on heating, refrigerant and air loops in heat pumps. Automatic calculation of superheating and subcooling for all common refrigerants.

- Measurement data storage and evaluation in a PC
- Printout on site with optional infrared printer
- Calculation of superheating and subcooling in real time

### testo 560

The professional solution for commissioning, service and maintenance. The testo 560 additionally has a high-quality vacuum sensor for the evacuation of heat pumps. The sensor measures the absolute pressure and displays the corresponding evaporation temperature of water.

- 4 temperature probe connections (2 x cable, 2 x wireless)
- High-quality sensor
- 30 refrigerants stored in instrument
- Vacuum sensor/evacuation (testo 560)



4-way valve block



Measurements on a heat pump

#### testo 556-1

testo 556-1, electronic refrigeration system analyser, brass connections, calibration protocol and batteries included

Part no. 0560 5563

#### testo 556-1 Set

testo 556-1 refrigeration system analyzer, Velcro surface probe, software with USB data cable, mains unit, lock to secure analyzer, system case for extensive accessories included

Part no. 0563 5561

#### testo 560-1

testo 560-1, electronic refrigeration system analyser with vacuum sensor, brass connections, calibration protocol and batteries included

Part no. 0560 5603

#### testo 560-1 Set

testo 560-1 refrigeration system analyser, Velcro surface probe, software with USB data cable, mains unit, lock to secure analyzer, system case for extensive accessories included

Part no. 0563 5602

Accessories Ordering data	Part no.
System case for measuring instrument and extensive accessories	0516 5602
Transport case for measuring instrument and accessories	0516 5013
Plug-in mains adapter, 5 VDC 500 mA with European adapter, 100-250 VAC, 50-60 Hz	0554 0447
Testo fast printer with wireless infrared interface, 1 roll thermal paper and 4 AA batteries	0554 0549
Spare thermal paper for printer (6 rolls), permanent ink	0554 0568

Technical data testo 556 / testo 560	
<b>Pressure</b>	
Meas. range	25 bar / 50 bar
Overload	50 bar / 100 bar
Accuracy	±0.5% fs (Class 0.5)
Resolution	0,1 bar
<b>Temperature</b>	
Meas. range	-100 to +200 °C
Accuracy	Class B ±(0,3 +0,005 t)
Resolution	0.1 °C
<b>Vacuum (testo 560 only)</b>	
Meas. range	0 to 200 hPa
Overload	3 bar (Sensor protected from high pressures)
Resolution	0,1 mbar

Probes	Illustration	Meas. range	Accuracy	t99	Part no.
Pipe wrap probe with Velcro for pipes from Ø 6 mm to Ø 120 mm, Pt 100, 2.9 m cable length	450 mm 20 mm	-100 to +400 °C	Class A	90 s	0609 5602
Robust, waterproof surface temperature probe, Pt100	114 mm Ø 5 mm Fixed cable 1.2 m	-50 to +400 °C	Class B	40 s	0609 1973
Efficient, robust air probe, Pt100	114 mm Ø 5 mm Fixed cable 1.2 m	-50 to +400 °C	Class A (-50 to +300 °C), Class B (remaining range)	70 s	0609 1773
Pipe wrap probe for pipe diameter 5 to 65 mm	Fixed cable	-50 to +120 °C	Class B	5 s	0609 5605
Current probe for measuring current consumption of compressors, with switchable measuring range	Fixed cable	0 to 20/200 A	0 to 9.9 A 4% 10 to 49.9 A 3% 50 to 200 A 2%		0554 5607

## Check your heating unit using an energy monitor

### Mobile 24 hour measurement without interfering with the heating system

In the majority of heating systems, the individual components are not optimally adapted to each other and to the supply requirement. This results in considerable energy-saving potential, which can be evaluated inexpensively and at short notice in the course of an inspection. The Testo energy monitor fulfils the requirements of E DIN EN 15378, and has proven itself over a long period in practical use.

The objective of the testo-ratiodom energy monitor procedure is to provide a detailed measurement record of the operational behaviour of the system during use. Similarly to an ECG in humans, differing measurement parameters of a heating system are automatically recorded over a defined period of time. This takes place without interference with the heating system. The testo-ratiodom energy monitor is based on established measurement technology and sophisticated software. This allows the objective recognition of the optimization potential of the individual system components and their interaction. Statements on energy efficiency can be made based directly on causes.

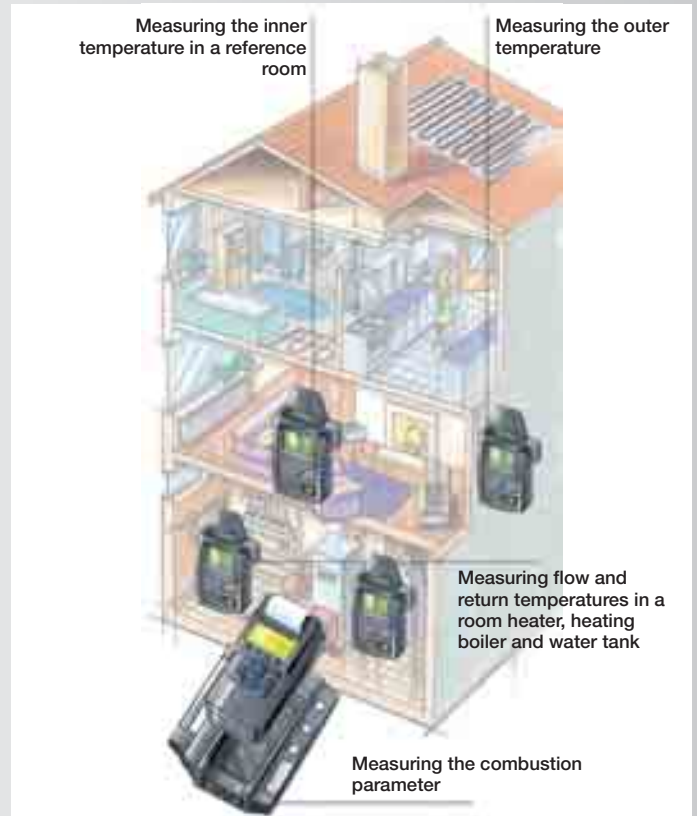

## Measuring with an energy monitor

A heating unit is used in this measurement.

The measurement involves the following steps:

- Recording of energy data relevant to building and heating system using the data sheet
- Mounting and installation of individual loggers by a specialist
- Independent logging of various readings by the energy monitor over a predefined time of 1 to 24 hours.

Following readings are taken:

Ambient temperature	TeRa	°C
Ambient humidity	FeRa	%RH
Outer temperature	TeAu	°C
Boiler/flow	VoKe	°C
Boiler/return	RüKe	°C
Heating/flow	VoHz	°C
Heating/return	RüHz	°C
Tank/flow	VoSp	°C
Tank/return	RüSp	°C
O <sub>2</sub> level in flue gas	O <sub>2</sub>	%
CO level in flue gas	CO	ppm
Combustion temp.	AT	°C
Flue gas temperature	FT	°C



The analysis procedure can be carried out by any trained staff. Additional expert analyses by experienced assessors are offered on request

## Basic analysis

### Exhaust gas loss:

In addition to the exhaust gas loss acc. to 1. BImSchV, the dynamic exhaust gas loss, i.e. the actual loss during use is calculated over the measurement time using the measurement values.

### Fuel value utilization:

The actual fuel value utilization – i.e. the information whether the fuel value effect is being utilized – is determined from the measured exhaust gas parameters and temperatures.

### Degree of utilization of boiler:

The degree of utilization of heat production is calculated taking all determined individual losses into consideration.

### Maximum heat load:

The maximum heat load is determined from the measurement values, in order to calculate the *boiler dimensions* and the *burner performance setting*.

### Degree of building efficiency:

The degree of building efficiency is determined from the max. heat load and the building data, and afterwards referred to the heated area used. Normed values are the basis for the building comparison. The output is made as an oil equivalent in  $l/m^2a$ .

### Heat requirement to fuel consumption ratio:

Fuel consumption is a crucial parameter for evaluating energy efficiency. In order to determine the scale of the potential for savings in the system technology, the heat requirement is determined from the maximum heat load, the climate data and the measurement results – and then placed in a ratio to the fuel consumption, based on area.

### Recommendations:

Automatic recommendations for the individual system components and parameters are made depending on the deviations of the recorded results from standard values.



## The complete solution in one set



### Testo energy monitor set at a glance

Energy monitor control unit with rechargeable battery and calibration protocol
Analysis box, equipped with O <sub>2</sub> , CO, energy monitor version
PC readout/conversion software with analysis and graphics functions, online measurement
Mini ambient air probe, 60 mm immersion depth, Tmax. +100 °C
Flue gas probe, 180 mm, 500 °C, 8 mm
Holder for flue gas probe
Hose with condensate drain and condensate container, 2 m
Measurement case (leather) with sections for measuring instruments and accessories
USB connection cable, connects instrument to PC
Serial connection cable for testo 350
testo 175-T2 temperature logger for measuring outer temperatures
testo 175-T3 temperature logger for measuring heater, burner and boiler temperatures, 3 off
testo 175-H2 humidity/temperature logger for measuring inner temperatures and ambient humidity
USB interface with PC connection cable for testo 175 with desk-top holders
Velcro probe for shaft up to 120 mm in diameter, 2 off
Pipe wrap probe for 5 mm – 65 mm pipe diameter, measures flow and return temperatures, 4 off
Lock for testo 175/177

Part no.      0563 0359



## Notes

## Notes



# Testo: At Your Service

Please send for more information:

Monitoring Instruments for Food Production, Transport and Storage  
Measurement Engineering for Restaurants, Catering and Supermarkets  
Measurement Engineering for Air Conditioning and Ventilation  
Measurement Engineering for Heating and Installation  
Measurement Solutions for Emissions, Service and Thermal Processes  
Measurement Solutions for Refrigeration Technology  
Stationary Measurement Solutions for Air Conditioning, Drying, Cleanrooms and Compressed Air  
Measurement Solutions for Production, Quality Control and Maintenance  
Measurement Solutions for Climate Applications in Industry  
Reference Measurement Technology for Industry

Measuring Instruments For Temperature  
Measuring Instruments for Humidity  
Measuring Instruments For Velocity  
Measuring Instruments for Pressure and Refrigeration  
Multi-Function Measuring Instruments  
Measuring Instruments for Flue Gas and Emissions  
Measuring Instruments for RPM, Analysis, Current/Voltage  
Measuring Instruments For Indoor Air Quality, Light And Sound  
Stationary Measurement Technology Humidity / Differential Pressure / Temperature / Process Displays  
Stationary Measurement Technology Compressed Air Humidity / Compressed Air Consumption

Subject to change without notice

0981 0274/msp/SI/A/01.2010



## Contents

### Flue gas analysis

testo 308	Electronic smoke tester for chimneysweeps and heating constructors	6
testo 327-1	The basic instrument for heating constructors and fitters	9
testo 327-2	The service instrument for heating constructors and chimneysweeps	10
testo 330-1 LL	Flue gas analysis with more convenience and reliability	12
testo 330-2 LL	The flue gas analyzer with integrated draught/gas zeroing	12
testo 350-S	Portable flue gas analysis system	20

### Installation

#### Temperature

testo 905-T2	Surface temperature measurement – spot-on	24
testo 922	Differential temperature measurement – at a glance	24
testo 174	Monitors ambient temperature – accurately and securely	25
testo 175-T3	Monitors temperature – long-term and uninterrupted	25
testo 875 and 881	Thermal imager with highest image quality	26
testo 845	Infrared measurement engineering for temperature with built-in humidity module	32
testo 830-T1/-T2/-T3	Non-contact temperature measurement – with laser sighting	34
testo 810	Air temperature and infrared surface temperature in one instrument	35

#### Druck

testo 510	Differential pressure 0 to 100 hPa – practical and robust	36
testo 312-2/-3	Pressure measurement for gas and water installation	38
Test system	Complete test system for gas and water installation	39
testo 312-4	Fulfilling all measurement tasks on gas heating systems and on gas and water pipes	40
testo 314	The DVGW-tested system for gas and water systems	42

#### Endoscopy / wood moisture

testo 606-1/-2	Material moisture, air moisture and temperature in one instrument	36
testo 319	Flexible fiberscope for fast diagnoses	49

#### Heat pumps

testo 556/560	Robust measuring instrument for commissioning, service and maintenance on heat pumps	50
---------------	--	----

### Safety

testo 317-2	Gas leak detector	43
testo 316-1	Detector for leaks on natural gas pipes	44
testo 316-2	The gas leak detector for a fast overview	44
testo gas detector	Gas sniffer – for detecting the smallest gas leaks	45
testo 317-1	Gas spillage detector for escaping flue gas	46
testo 317-3	Carbon monoxide warning in the environment	46
testo 315-2	CO warning measurement – for your safety	47
testo 315-1	Allround CO measurement – for safety and service	48
Energy monitor	The „ECG“ measuring instrument for heating systems	52

## Icons



Backlit display



User-friendly operation due to menu-driven functions



SoftCase or TopSafe to protect instrument or to provide instrument with protection from water ingress



Shock-proof



Infrared printer  
Reliable printout of measurement results on site



Barcode reader  
Used for data management, customer allocation and scheduling



RS 232 interface  
For easy connection to all sector software



Battery and rechargeable battery operation possible



Battery can be recharged in instrument

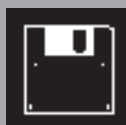

Measurement data store integrated in measuring instrument



Radio probes for wireless connection